



# Installation Instructions

## 615179

### 2016-20 JEEP GRAND CHEROKEE & DODGE DURANGO 3.6L ENGINE

NOT LEGAL FOR SALE OR USE ON ANY POLLUTION-CONTROLLED MOTOR VEHICLE IN CALIFORNIA OR IN STATES THAT HAVE ADOPTED CALIFORNIA EMISSION PROCEDURES.

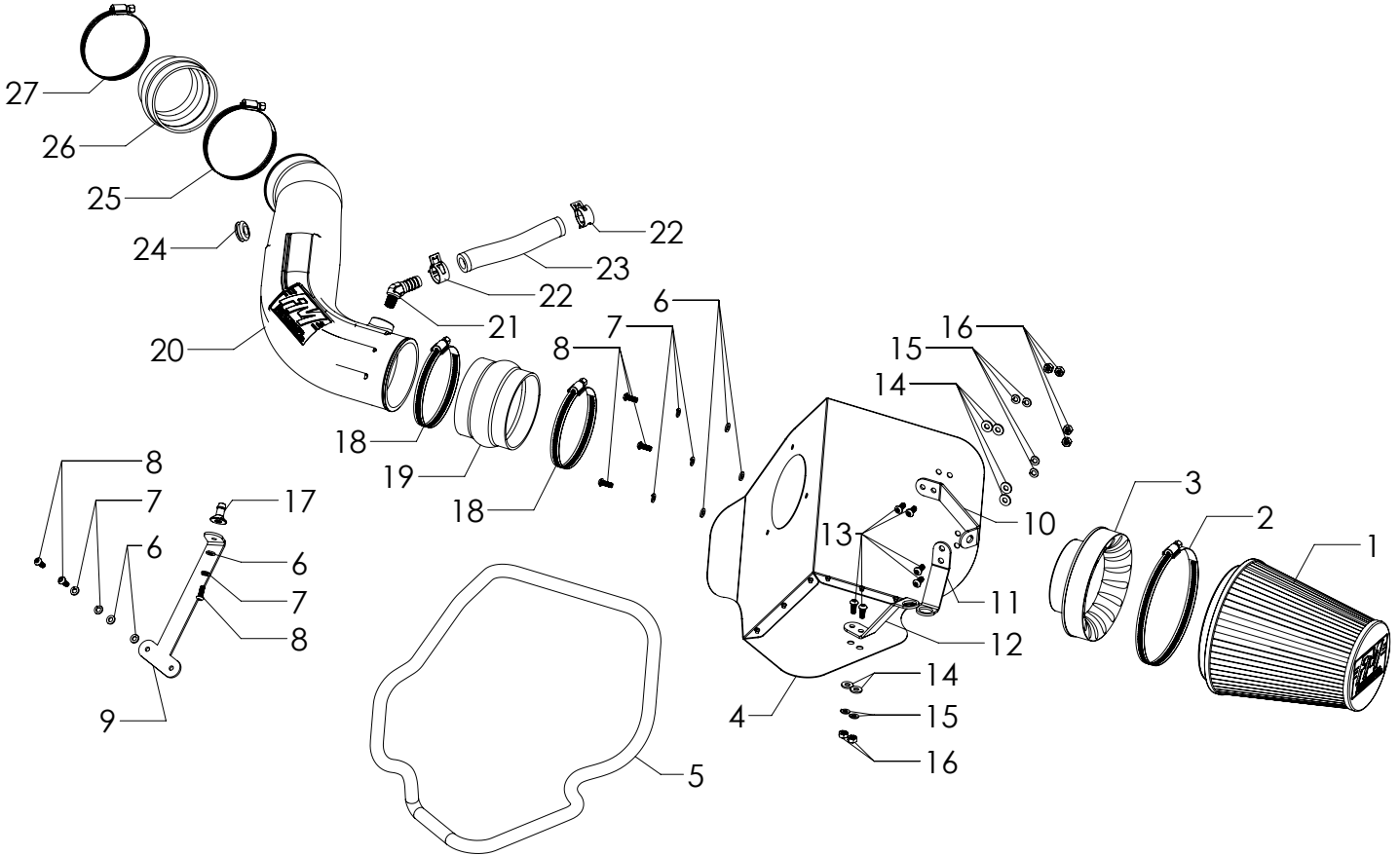

ITEM NO.	PART NUMBER	DESCRIPTION	QTY.
1	AF1001	AIR FILTER, 8-5/8" x 6" DIA	1
2		SCREW CLAMP, #104 (4-1/8" - 7")	1
3	AF6002	ADAPTER, AIR FILTER 4" x 6"	1
4	AF3058	HEAT SHIELD	1
5	49000061	GASKET, HEAT SHIELD	66"
6	HW319	FLAT WASHER, M6	6
7	HW318	LOCK WASHER, M6	6
8	HW244	SCREW, M6 x 1.0 x 16MM	6
9	AF5076	BRACKET 1	1
10	AF5077	BRACKET 2	1
11	AF5078	BRACKET 3	1
12	AF5079	BRACKET 4	1
13	HW245	SCREW, 1/4"-20 x 5/8"	6
14	HW320	FLAT WASHER, 1/4"	6

ITEM NO.	PART NUMBER	DESCRIPTION	QTY.
15	HW322	LOCK WASHER, 1/4"	6
16	HW115	NUT, 1/4"-20	6
17	AF7001	BARBED PIN, M6 x 1.0	1
18	MC400H	SCREW CLAMP, #64 (3-9/16" - 4-1/2")	2
19	AF4005	COUPLER, FLEX 4" I.D. x 3" L	1
20	AF2058	INTAKE TUBE	1
21	AF4041	ELBOW, 45°, 5/8" BARB TO 1/4" NPT MALE	1
22	MC004P	PINCH CLAMP, 5/8" HOSE	2
23	49000068	HOSE, 5/8" I.D.	6"
24	AF4008	GROMMET, 1-1/16" OD x 1/2" ID x 3/16" THK	1
25	MC350H	SCREW CLAMP, #56 (3-1/16" - 4")	1
26	AF4057	COUPLER, FLEX 3-1/2" I.D. - 3" I.D. x 2-1/2" L	1
27	MC314H	SCREW CLAMP, #52 (2-13/16" - 3-3/4")	1

## REVIEW THE INSTRUCTIONS AND VERIFY THE KIT CONTENTS:

1. Please take a moment to read and understand these instructions before installing your Flowmaster performance air intake kit.



2. Use the parts drawing and list (front page) to verify your kit's contents.

In the unlikely event that any parts are missing, please contact Flowmaster Technical Support for replacements.

To simplify assembly and avoid cross-threading fasteners, identify and separate the 1/4-20 screws (item 13) (used with nuts (16)), and the M6 screws (8) (used with filter adapter (3) and barbed pin (17)).

## REMOVE THE FACTORY AIR INTAKE SYSTEM:

### NOTES

- We highly recommend that you retain all factory air intake system parts.
- Please refer to vehicle manufacturer's recommendations regarding removal of factory components.
- Disconnecting the negative battery cable erases pre-programmed electronic memories. Write down all memory settings before disconnecting the negative battery cable. Some radios will require an anti-theft code to be entered after the battery is reconnected. The anti-theft code is typically supplied with your owner's manual. In the event your vehicle's anti-theft code cannot be recovered, contact an authorized dealership to obtain your vehicle's anti-theft code.

3. Turn off the vehicle's ignition and disconnect the negative battery cable. **Failure to disconnect the battery may cause the CHECK ENGINE light to illuminate after the air intake kit is installed.**



4. On the engine appearance cover, lift the access panel and remove. Then remove the screw and appearance cover.

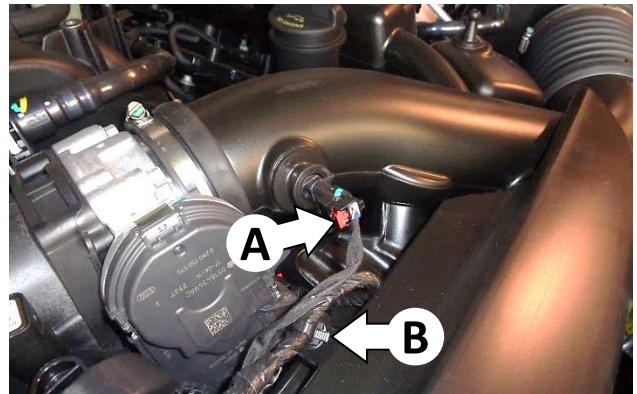

5. Disconnect the inlet air temperature sensor plug by lifting the latch (A) and pulling the plug straight off the sensor. Then carefully pry the wire loom clamp (B) from the resonator chamber.

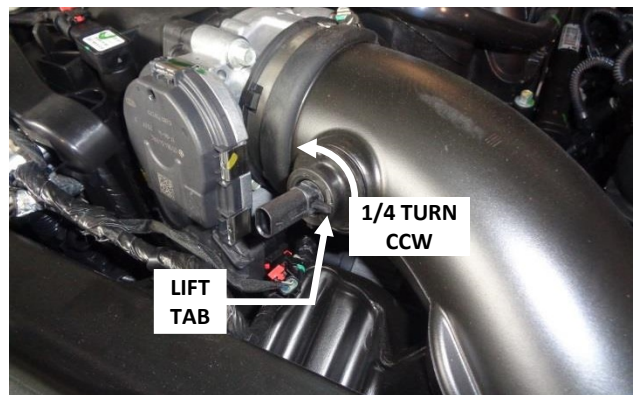

6. Remove the air temp sensor by lifting the locking tab and turning the sensor a quarter-turn counter-clockwise while pulling straight out. Store the sensor in a safe location until reinstallation.



7. Loosen the screw clamp that secures the air inlet duct to the throttle body.

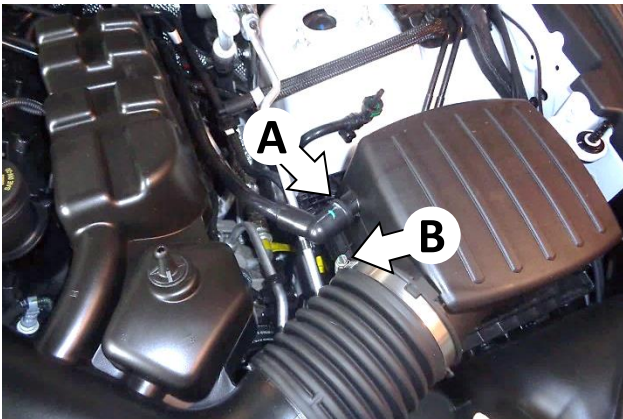

8. Disconnect the PCV hose from the airbox (A), then loosen the screw clamp (B) that secures the duct to the airbox.



9. Separate the duct from the throttle body and the airbox, then remove it from the vehicle.



10. Lift enough of the engine compartment trim seal off the airbox snorkel to allow removal of the airbox.



11. Remove the airbox from the vehicle by firmly pulling it straight up.

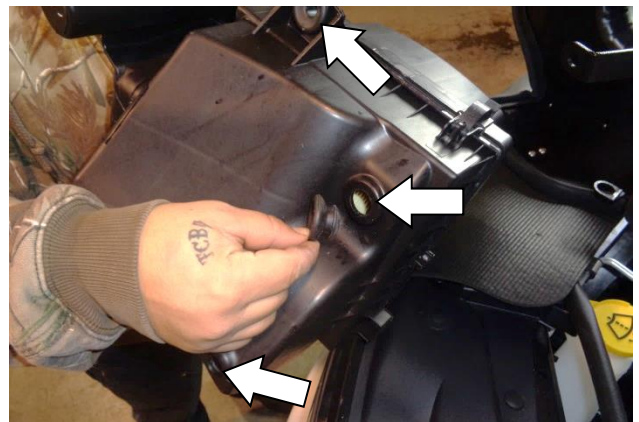

12. Remove any 2 of the 3 rubber mount grommets from the bottom of the airbox and retain for use at Step 19.

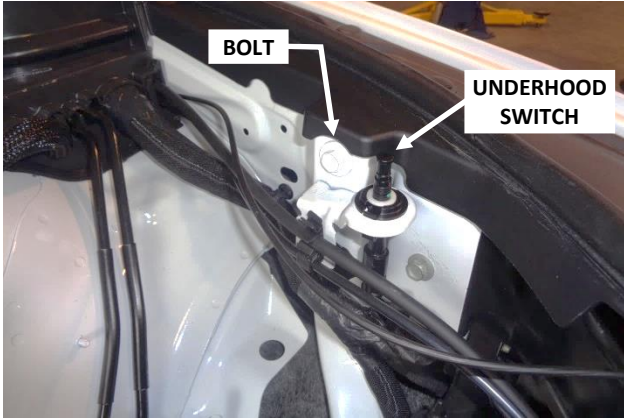

13. Remove the bolt located just behind the hood alarm switch and retain it for use at **Step 21**.

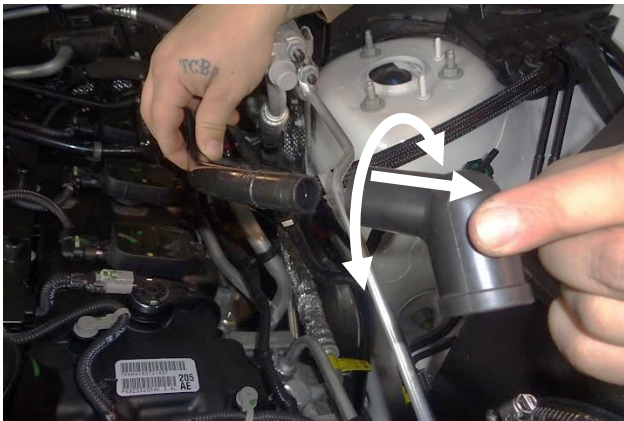

14. Remove the rubber elbow from the end of the PCV tube by carefully twisting it back and forth while pulling it straight off.

**ASSEMBLE AND INSTALL YOUR FLOWMASTER PERFORMANCE AIR INTAKE SYSTEM:**

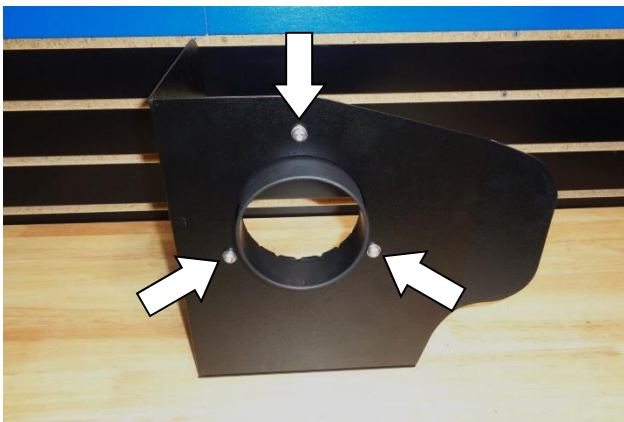

15. Assemble the air filter adapter (3) to the heat shield (4) using M6 screws (8), lock washers (7) and flat washers (6).



16. Attach the gasket (5) to the heat shield. Starting at the corner shown, firmly press the gasket onto the edge, gradually working around the heat shield. When you return to the starting corner, trim the gasket to fit using metal-cutting shears.

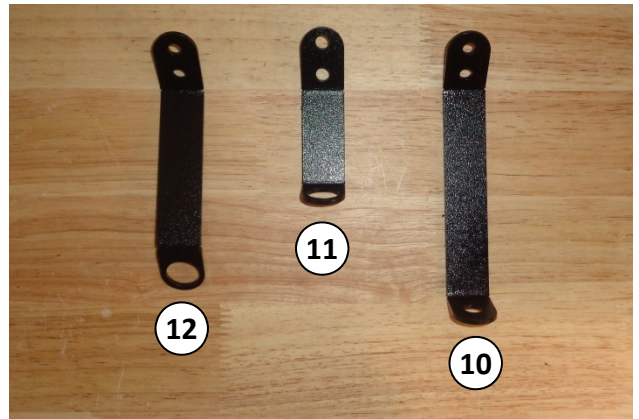

17. Identify airbox brackets (12), (11) and (10) as shown above.

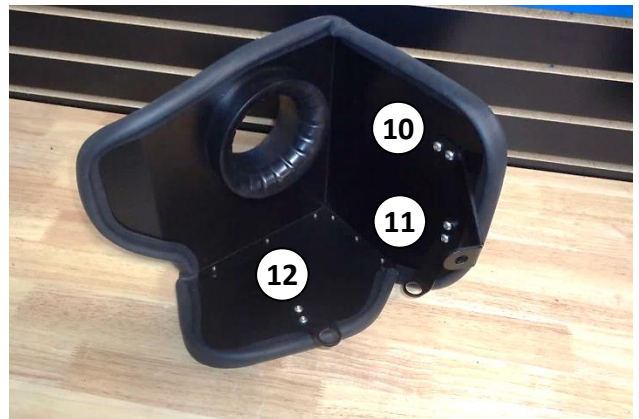

18. Attach the brackets to the heat shield according to this photo and the parts drawing, using ¼-20 screws (13) (on the bracket side), and flat washers (14), lock washers (15) and nuts (16) (on the heat shield side).



19. Push the two rubber grommets removed from the airbox at **Step 12** into brackets (12) and (11) as shown.

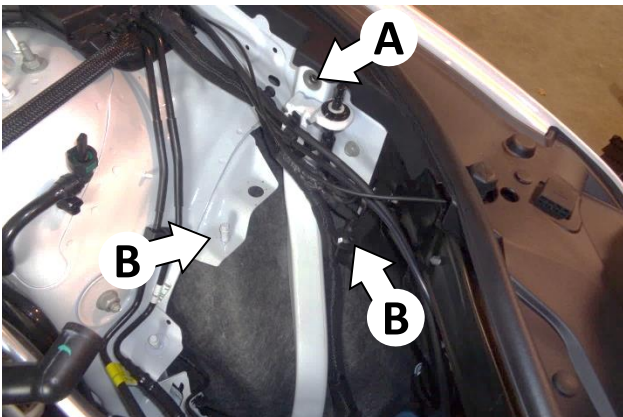

20. Note the locations of the three factory mounting points – bolt hole (A), and pins (B).

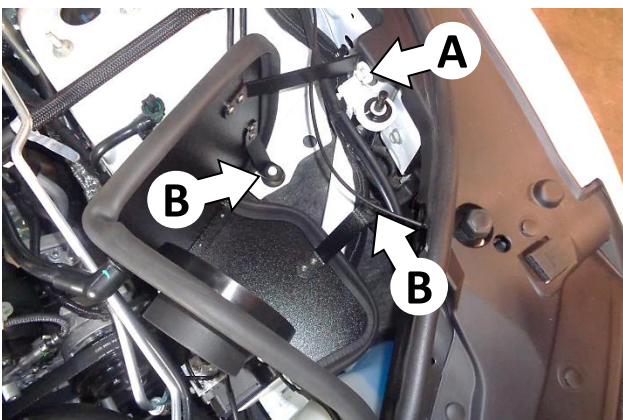

21. Install the assembled heat shield in the vehicle by pushing the two grommets onto the pins (B). Then install the stock bolt (removed at **Step 13**) through the bracket (A).



22. Attach the barbed pin (17) to bracket (9) using an M6 screw (8), lock washer (7) and flat washer (6).

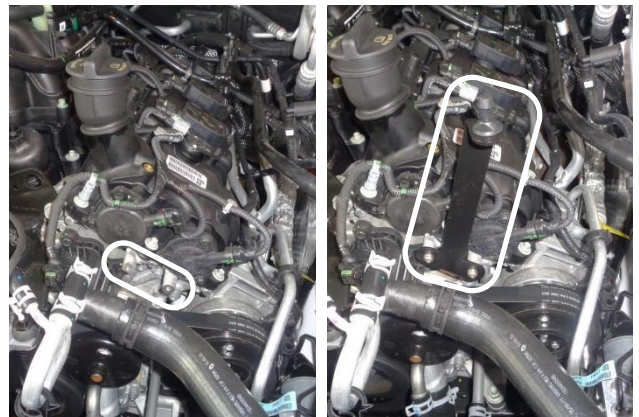

23. Locate the 2 screw holes on the engine as shown, and attach the bracket using M6 screws (8), lock washers (7) and flat washers (6).



24. Apply 2 wraps of nylon thread tape to the threads of the barbed elbow (21), and install it in the intake tube (20).



25. Install the 2 large screw clamps (18) on the 4" flex coupler (19). Then install the coupler on the filter end of the intake tube. **Do not tighten the clamps at this time.**



26. Insert the rubber grommet (24) into the tube. Moistening the grommet with soapy water will ease insertion.



27. Carefully push the air temp sensor into the grommet, orienting the tab away from the throttle body opening. Moistening the grommet I.D. with soapy water will ease insertion. **Note that the tab does not sit flush against the grommet – there will be a slight gap.**



28. Install the medium and small screw clamps (25) and (27) on the 3-1/2" - to - 3" coupler (26). Push the coupler all the way onto the throttle body and tighten only the small (throttle body) clamp.



29. Install the intake tube in the vehicle, but do not tighten any screw clamps yet.

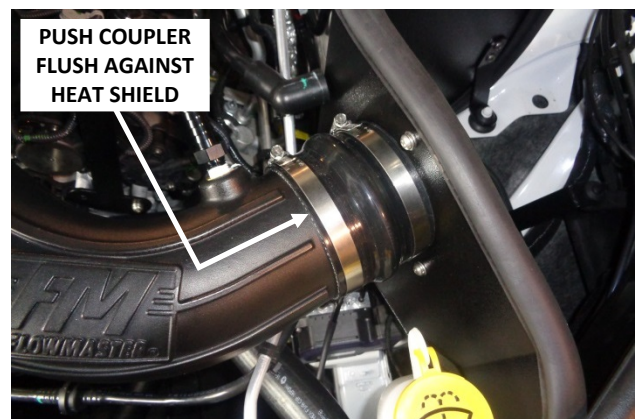

30. Push the flex coupler up against the heat shield and tighten only the filter adapter clamp.



31. Center the intake tube between the couplers (so that there is roughly an equal amount of the tube inside each coupler), and tighten the two intake tube clamps.



32. Push one end of the 5/8" I.D. hose (23) onto the PCV tube. Cut the hose to fit the barbed fitting in the intake tube, and secure at both ends using pinch clamps (22). NOTE: Point the ears on the clamps toward the heat shield, so that they do not hit the engine cover when it is installed at **Step 35**.

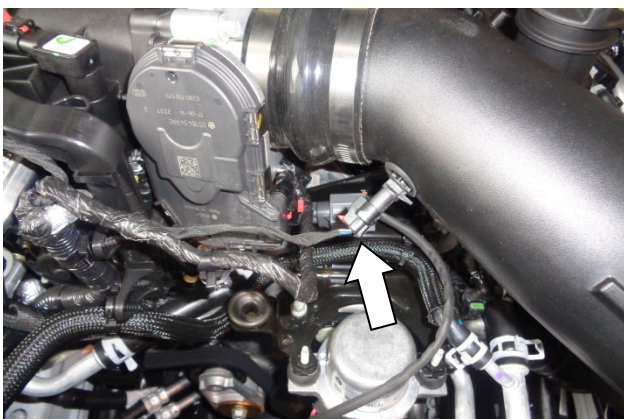

33. Connect the air temp sensor plug to the sensor and check the plug for security.



34. Reinstall the engine appearance cover, but not its screw.



35. Verify there is no contact between the engine cover and the pinch clamp on the PCV tube. Adjust the pinch clamp if required.



36. Reinstall the engine cover screw, and then the access panel.

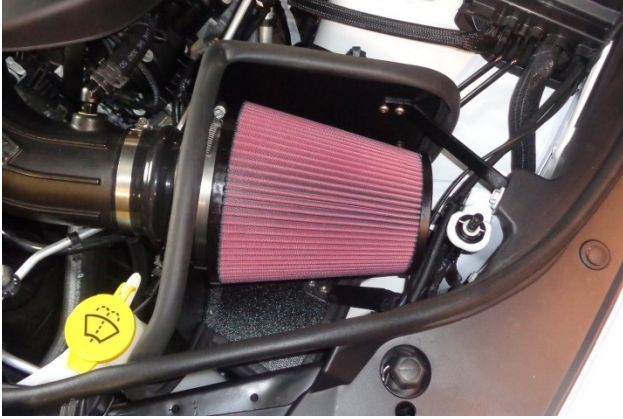

37. Place screw clamp (2) on air filter (1), install the filter on the filter adapter, and tighten the clamp.



**Congratulations, the installation of your FLOWMASTER performance air intake kit is now complete!**

