

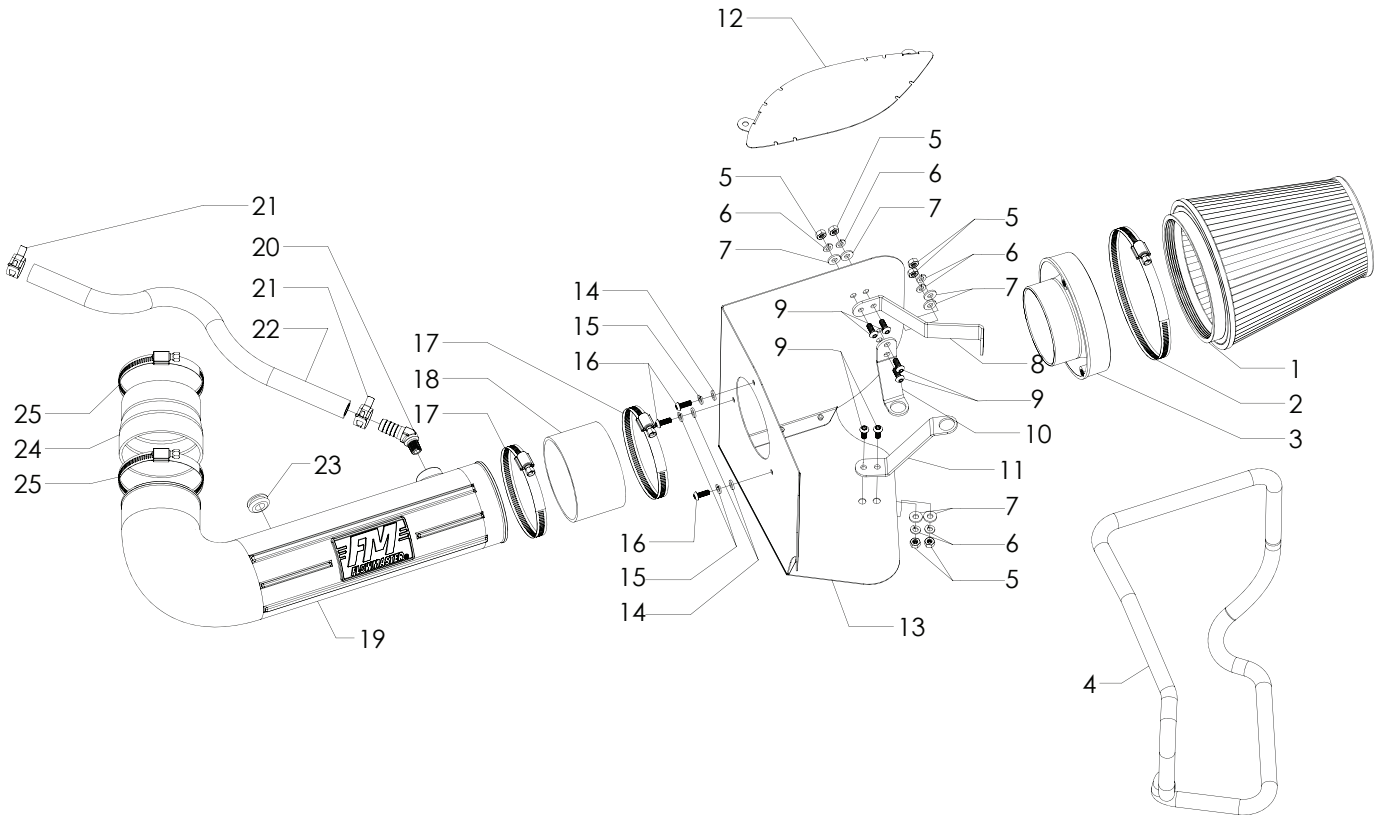

Installation Instructions  
**615182**  
**2011-20 DODGE DURANGO**  
**& JEEP GRAND CHEROKEE**  
**5.7L HEMI ENGINE**



ITM #	PART #	DESCRIPTION	QTY.
1	AF1001	8 $\frac{5}{8}$ " x 6" Dia. Air Filter	1
2		#104 (4 $\frac{1}{8}$ "-7") Screw Clamp	1
3	AF6002	4" x 6" Air Filter Adapter	1
4	49000061	Heat Shield Gasket	1
5	HW115	$\frac{1}{4}$ "-20 Nut	6
6	HW322	$\frac{1}{4}$ " Lock Washer	6
7	HW320	$\frac{1}{4}$ " Flat Washer	6
8	AF5061	Bracket 1	1
9	HW245	$\frac{1}{4}$ "-20 x $\frac{5}{8}$ " Screw	6
10	AF5078	Bracket 3	1
11	AF5079	Bracket 4	1
12	AF5051	Intake Block-Off Plate	1
13	AF3058	Airbox-Complete	1

ITM #	PART #	DESCRIPTION	QTY.
14	HW319	M6 Flat Washer	3
15	HW318	M6 Split Lock Washer	3
16	HW244	M6 x 1.0 x 16MM Screw	3
17	MC400H	#64 (3 $\frac{3}{16}$ " to 4 $\frac{1}{2}$ ") Screw Clamp	2
18	AF4050	4" IDx2- $\frac{1}{2}$ " L Straight Coupler	1
19	AF2071	Intake Tube	1
20	AF4041	$\frac{5}{8}$ " Barb $\frac{1}{4}$ " Male 45° Elbow	1
21	MC004P	$\frac{5}{8}$ " Hose Pinch Clamp	2
22	49000068	$\frac{5}{8}$ " I.D. Hose	1
23	AF4008	1 $\frac{1}{16}$ " x $\frac{1}{2}$ " ID x $\frac{3}{16}$ " Grommet	1
24	AF4072	3 $\frac{3}{4}$ "-3 $\frac{1}{2}$ " IDx3"L Reduc. Coupler	1
25	MC350H	#56 (3 $\frac{3}{16}$ "-4") Screw Clamp	2

## OVERVIEW:



1. Take a moment to read and understand these instructions before installing your Flowmaster performance system.

**NOTE:** Disconnecting negative battery cable erases pre-programmed electronic memories. Write down all memory settings before disconnecting negative battery cable. Some radios will require an anti-theft code entry once battery is reconnected. Find your anti-theft code either in vehicle owners manual or through your authorized dealership.

2. Turn off vehicle's ignition and disconnect negative battery cable. **Failure to disconnect battery may cause CHECK ENGINE light to illuminate once air intake kit is installed.**

## REMOVE FACTORY AIR INTAKE SYSTEM:



3. Lift and remove engine cover. Retain for later re-use.

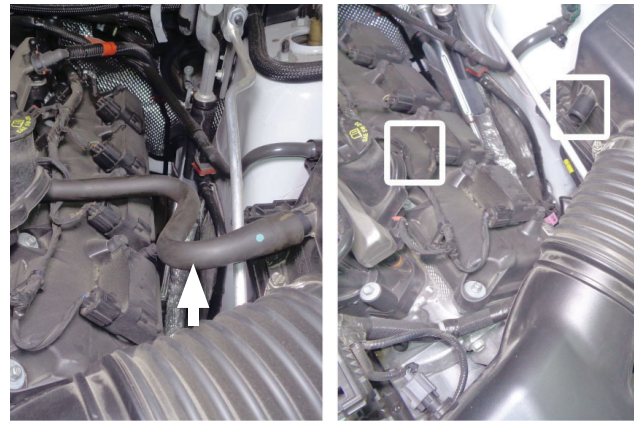

4. Disconnect PCV hose from oil fill and airbox then remove it from engine compartment.



5. Unplug connector from IAT sensor on intake tube.



6. Loosen screw clamp then disconnect intake tube from airbox.



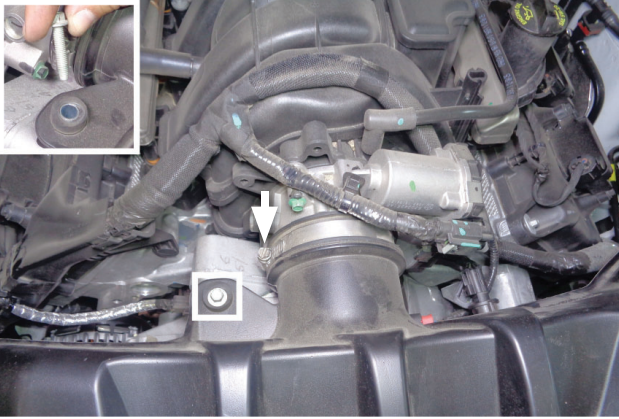

7. Loosen screw clamp holding resonator to throttle body then remove screw on resonator.



8. Remove resonator from engine compartment.



9. Remove IAT sensor from resonator, remove o-ring from IAT sensor then retain sensor for re-use.



10. Unclip trim seal from corner of inlet duct.



11. Pull airbox up sharply to release it from its mount grommets then remove it from engine compartment.

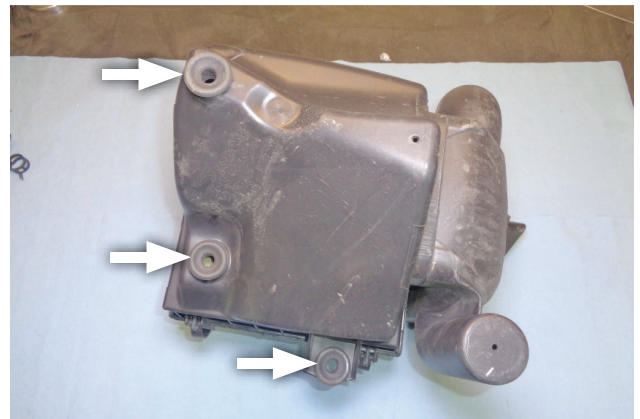

12. Remove 2 of the 3 grommets from bottom of airbox and retain for re-use.



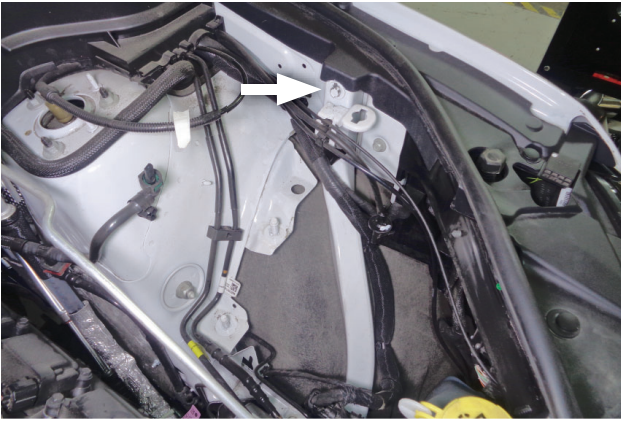

13. Remove bolt indicated from vehicle and retain for re-use.

**ASSEMBLE AND INSTALL FLOWMASTER PERFORMANCE AIR INTAKE SYSTEM:**

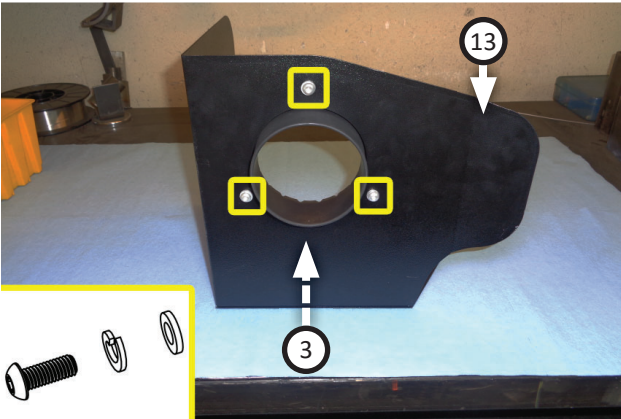

14. Secure air filter adapter (3) to heat shield (13) using screws (16), lock washers (15) and flat washers (14).

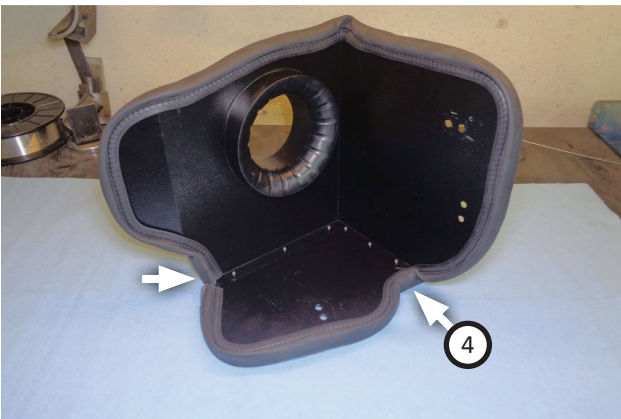

15. Starting at corner indicated, press **heat shield gasket (4)** gradually around edge of heat shield then trim to fit.

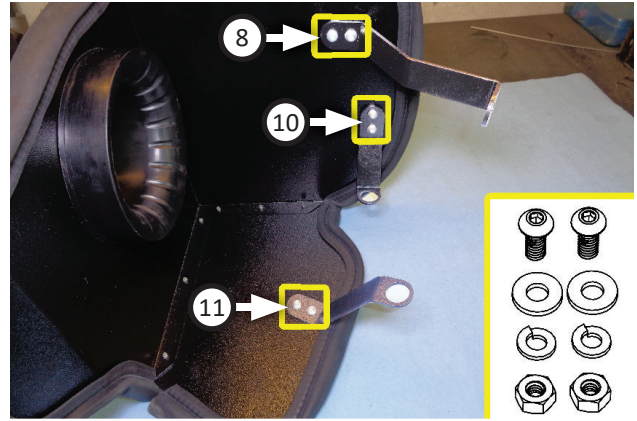

16. Attach **brackets (8, 10, 11)** to heat shield using **screws (9)** on bracket side through **flat washers (7)**, **lock washers (6)** and **nuts (5)** on heat shield side.

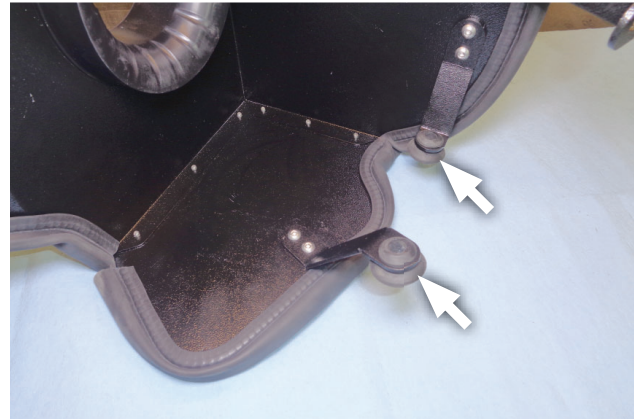

17. Push grommets (x2) (removed step 12) into brackets as shown.

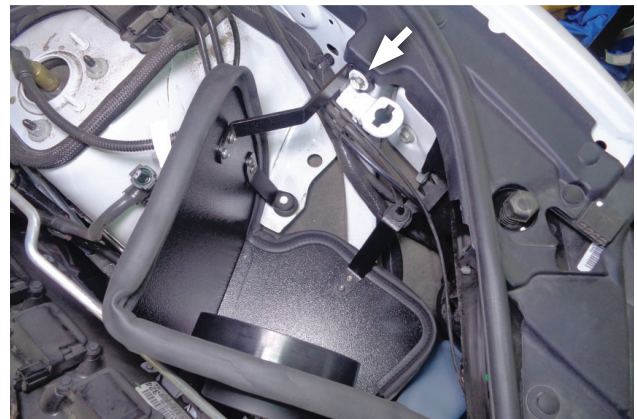

18. Install assembled heat shield into vehicle by pushing grommets (x2) onto pins. Re-install stock bolt (removed step 13) onto vehicle mount through bracket.



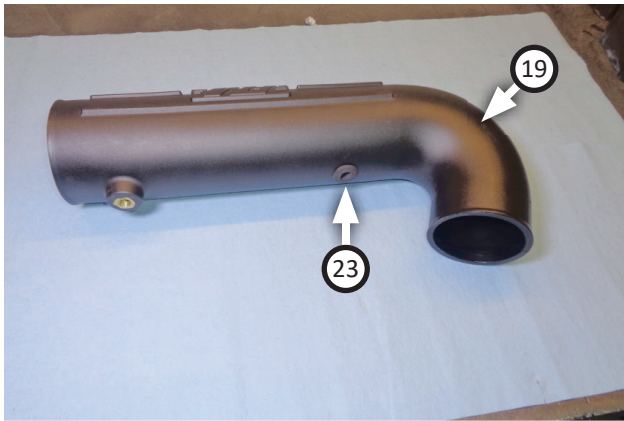

19. Insert **grommet (23)** into **intake tube (19)**.  
Moistening grommet with soapy water will ease insertion.

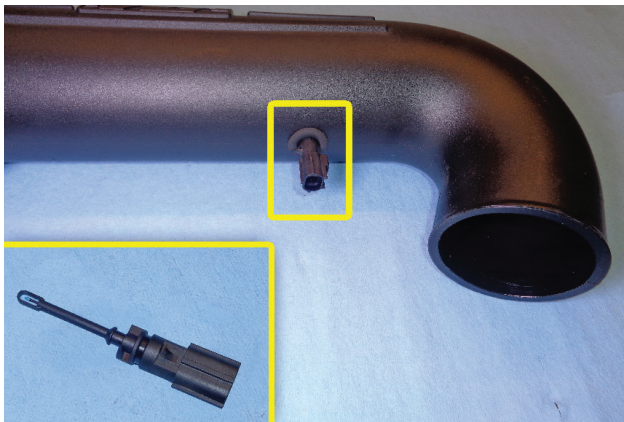

20. Insert IAT sensor (removed step 9) into intake tube at grommet oriented as shown.

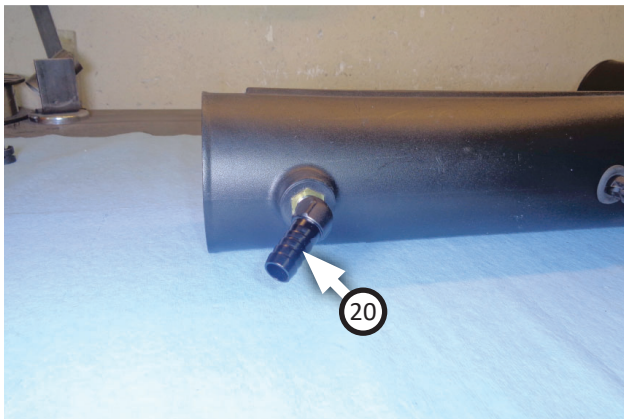

21. Apply 2 wraps of nylon thread tape to threads of **barbed elbow (20)** then install it into intake tube.

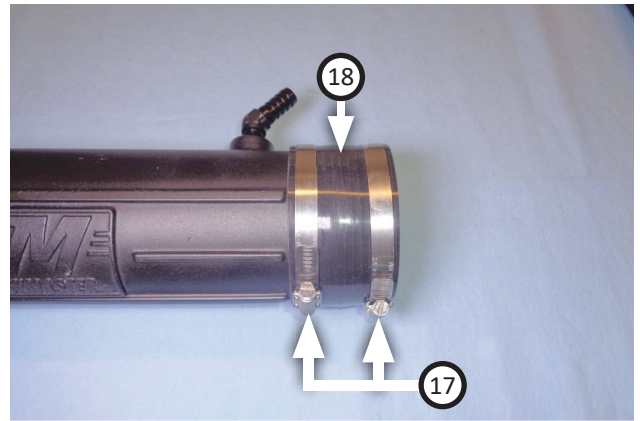

22. Fit **straight coupler (18)** and (x2) **screw clamps (17)** onto filter end of intake tube.

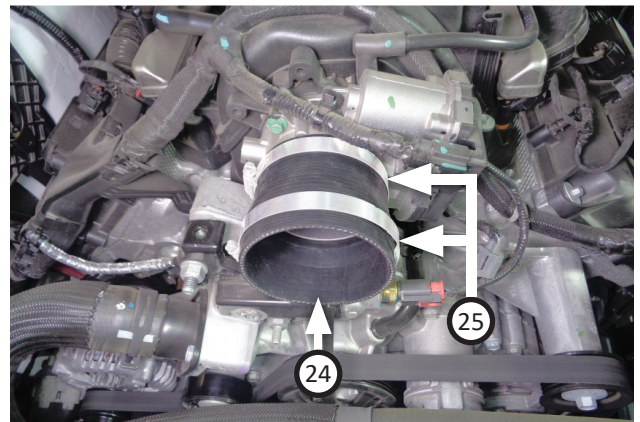

23. Fit tapered end of **reducer coupler (24)** and (x2) **screw clamps (25)** onto throttle body then push coupler fully against stops.



24. Set intake tube into place between heat shield and throttle body as shown without tightening screw clamps.





25. Push couplers flush against heat shield and throttle body before fastening outermost screw clamps (x2). Center intake tube between couplers then tighten remaining screw clamps (x2).



28. Re-install engine cover (removed step 3).



26. Plug connector into IAT sensor on intake tube.



29. Route hose over to barbed elbow then trim to fit.

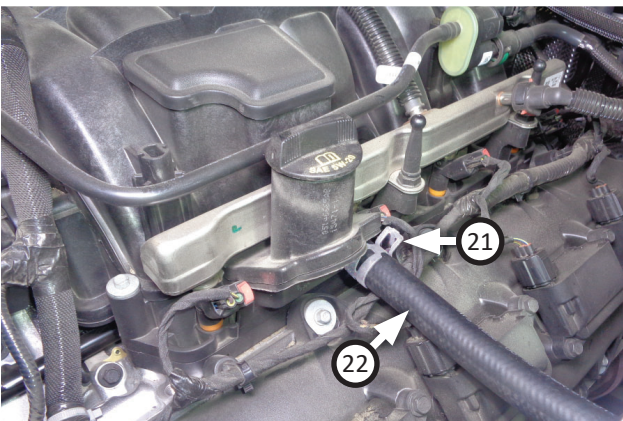

27. Place **pinch clamp (21)** onto **hose (22)** then connect hose to oil fill.

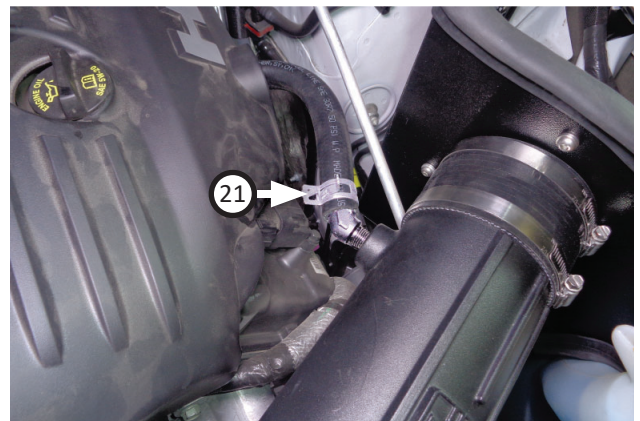

30. Place **pinch clamp (21)** onto loose end of hose then connect hose to barbed elbow on intake tube.



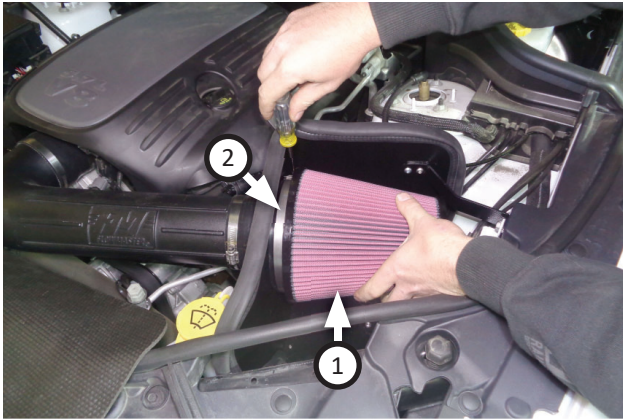

31. Place **screw clamp (2)** on **air filter (1)** then install filter onto adapter and tighten clamp.

#### OPTIONAL BLOCK-OFF PLATE INSTALL:



32. **This step applies only to Durango RT:** Remove screws and vent from underside of hood. Retain for re-use in step 33.

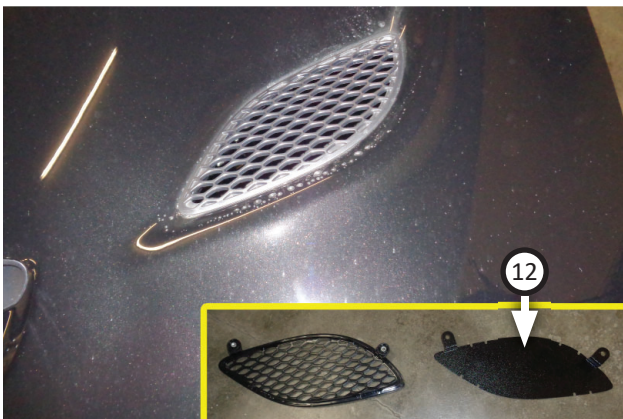

33. **This step applies only to Durango RT:** Re-install vent and **intake block-off plate (12)** in place on hood and secure using screws (removed step 32).



Congratulations, the installation of your FLOWMASTER performance air intake kit is now complete!

#### FILTER MAINTENANCE:

We recommend you clean and oil your air filter at 25,000 mile intervals using Flowmaster's Filter Refresh Kit (PN 615001). Visit our website or your Flowmaster distributor for details.

