

# INSTALLATION INSTRUCTIONS

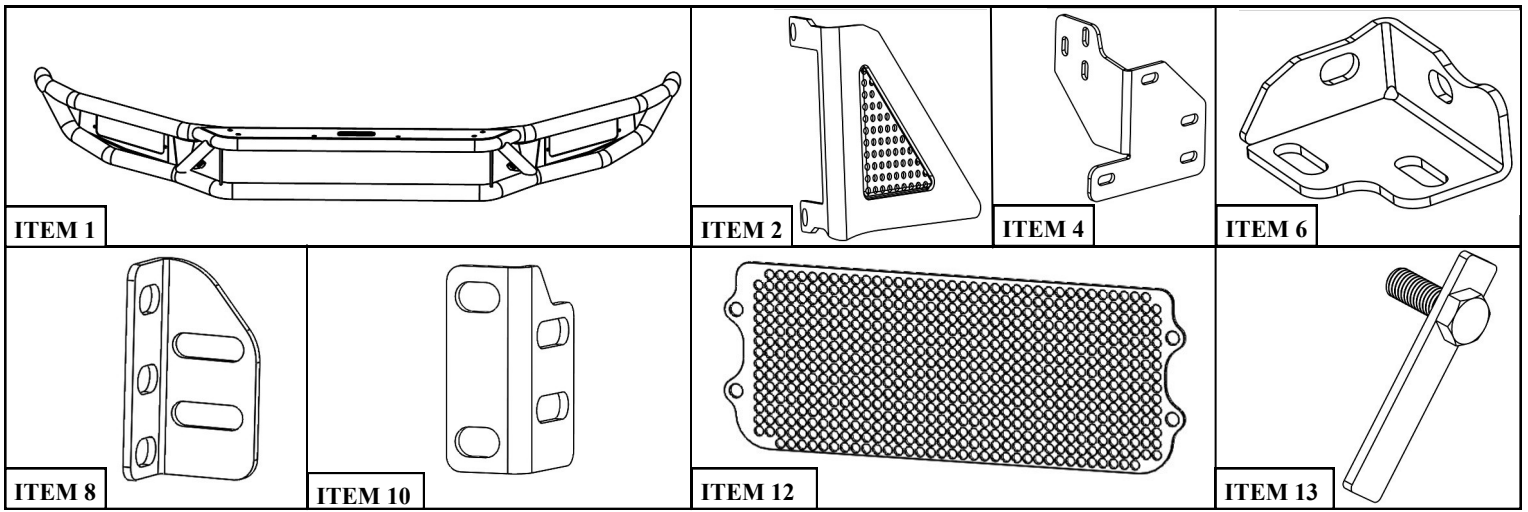
## OUTLAW FRONT BUMPER



**APPLICATION:**  
2016 - 2018 Chevrolet Silverado 1500  
**PART NUMBER:**  
58-61005

CONTENT			
ITEM	QUANTITY	DESCRIPTION	TOOLS NEEDED
1	1	FRONT BUMPER ASSEMBLY	18MM WRENCH
2,3	2	MESHED CORNER COVER, DRIVER (2) AND PASSENGER (3)	5MM ALLEN WRENCH
4,5	2	FRAME BRACKET, DRIVER (4) AND PASSENGER (5)	13MM SOCKET
6,7	2	SUPPORT BRACKET, DRIVER (6) AND PASSENGER (7)	17MM SOCKET
8,9	2	LED SLIDER BRACKET, DRIVER (8) AND PASSENGER (9)	19MM SOCKET
10,11	2	LED L-BRACKET, DRIVER (10) AND PASSENGER (11)	13MM WRENCH
12	2	LED MESHED SIDE COVER	17MM WRENCH
13	2	M10 BOLT PLATE	19MM WRENCH
14	6	M12 HEX HEAD BOLT (BLACK ZINC)	10MM SOCKET
15	12	M12 FLAT WASHER (BLACK ZINC)	10MM WRENCH
16	6	M12 SPLIT LOCK WASHER (BLACK ZINC)	PLYER TOOL
17	6	M12 HEX NUT (BLACK ZINC)	RATCHET
18	8	M8 CARRAIGE BOLT (BLACK ZINC)	TORQUE WRENCH
19	8	M8 HEX NUT (BLACK ZINC)	MASKING TAPE
20	8	M8 FLAT WASHER (BLACK ZINC)	MARKER
21	8	M8 SPLIT LOCK WASHER (BLACK ZINC)	MEASURING TAPE
22	4	M8 BUTTON HEAD BOLT (BLACK ZINC)	SAW/SHARP BLADE
23	4	M8 SERRATED FLANGE NUT (BLACK ZINC)	
24	2	M10 HEX NUTS (BLACK ZINC)	
25	2	M10 LOCK WASHERS (BLACK ZINC)	
26	4	M10 FLAT WASHERS (BLACK ZINC)	
27	2	M10 HEX BOLTS (BLACK ZINC)	
28	2	M10 SERRATED FLANGE NUTS (BLACK ZINC)	

**ANTI-SEIZE LUBRICANT MUST BE USED ON ALL STAINLESS STEEL FASTENERS TO PREVENT THREAD DAMAGE AND GALLING**



### PROCEDURE

1. Remove contents from box, verify if all parts listed are present and free from damage. Carefully read and understand all instructions before attempting installation.  
**Failure to identify damage before installation could lead to a rejection of any claim.**

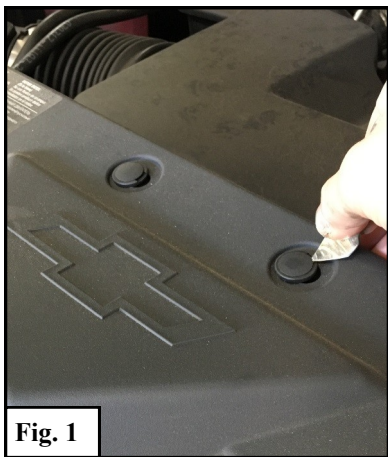


Fig. 1

2. Remove stock bumper
  - a. Open the hood of the vehicle and remove the plastic cover at the front using a pry tool. See **Figure 1**.
  - b. Remove the four bolts holding the grill in place and uninstall the grill. See **Figure 2**.
  - c. Remove the braces on each side of the vehicle by removing the bolts indicated in **Figure 3**.
  - d. Disconnect all electrical connections to the stock bumper.
  - e. Remove the two bolts indicated in **Figure 4** on the driver's side of the vehicle. Repeat procedure on the passenger's side.
  - f. Remove stock bumper. See **Figure 5**.



Fig. 2

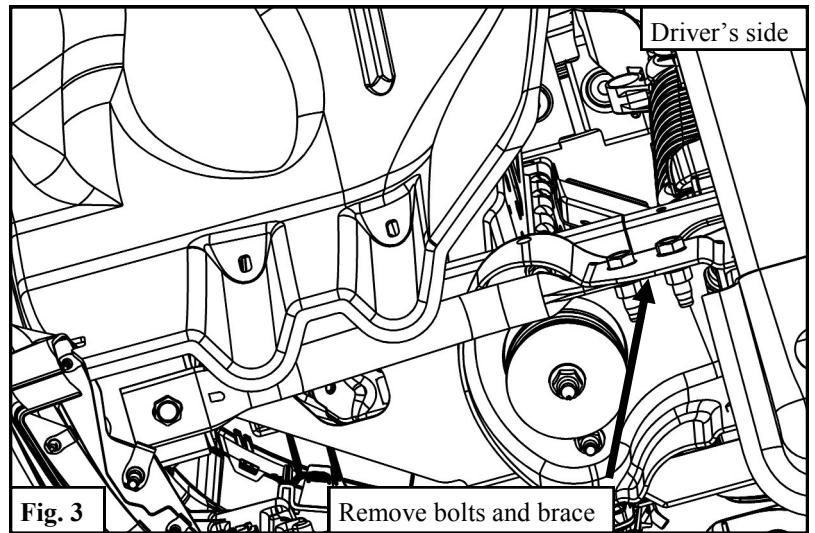
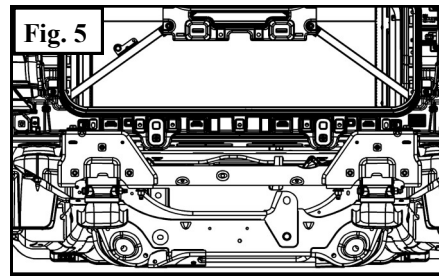
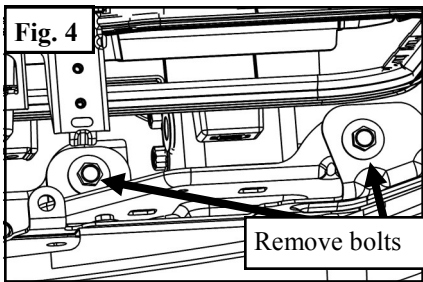


Fig. 3

Remove bolts and brace

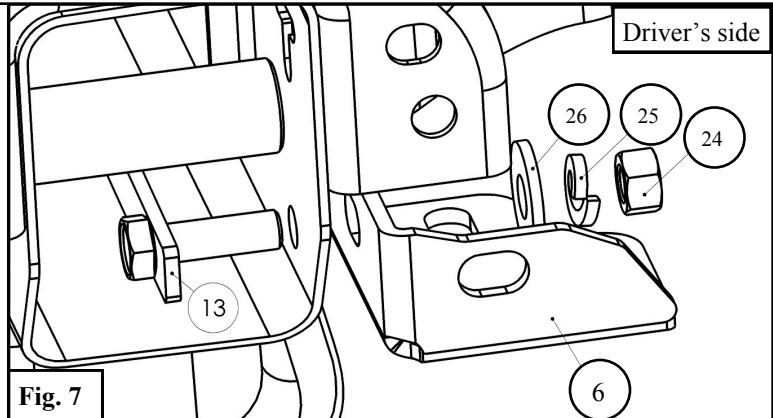
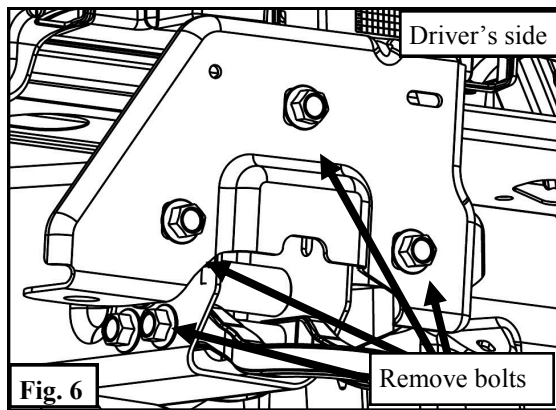


- On both sides of the vehicle, remove the tow hooks and bracket shown in **Figure 6**.

**Note 1:** Tow hooks and bracket will not be reused.

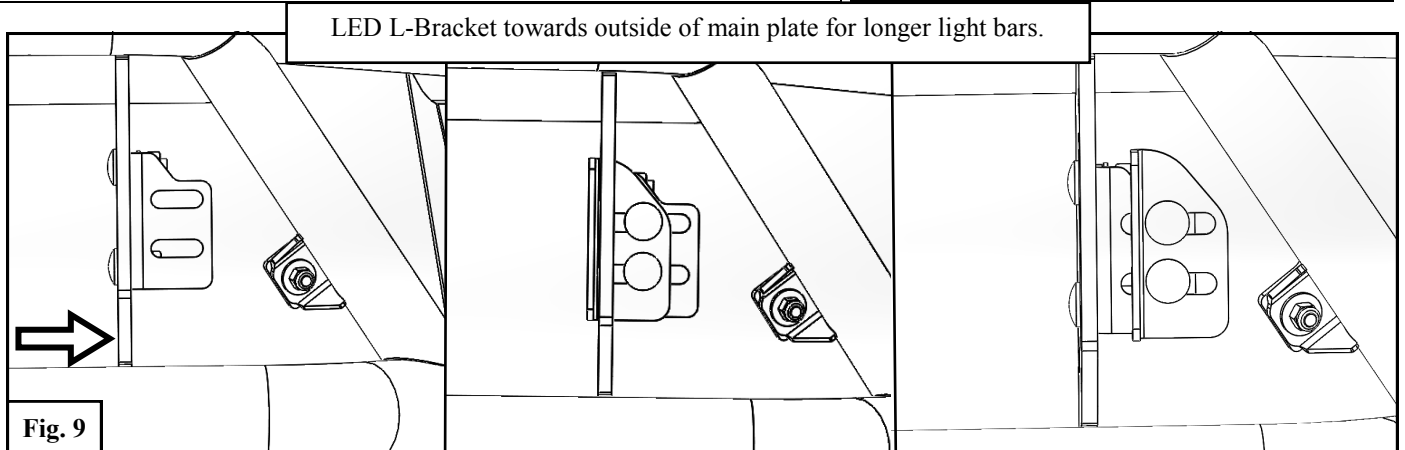
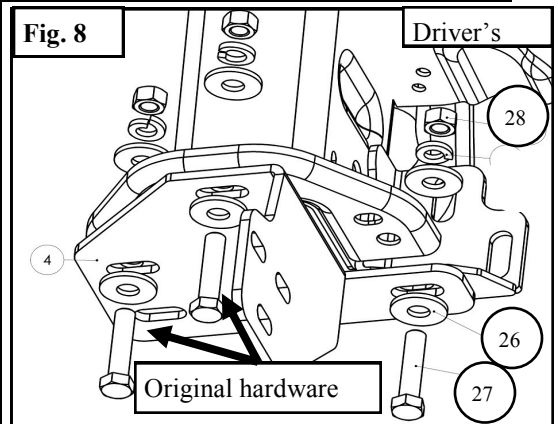
**Note 2:** Save four of the bolts and associated hardware from the brackets.

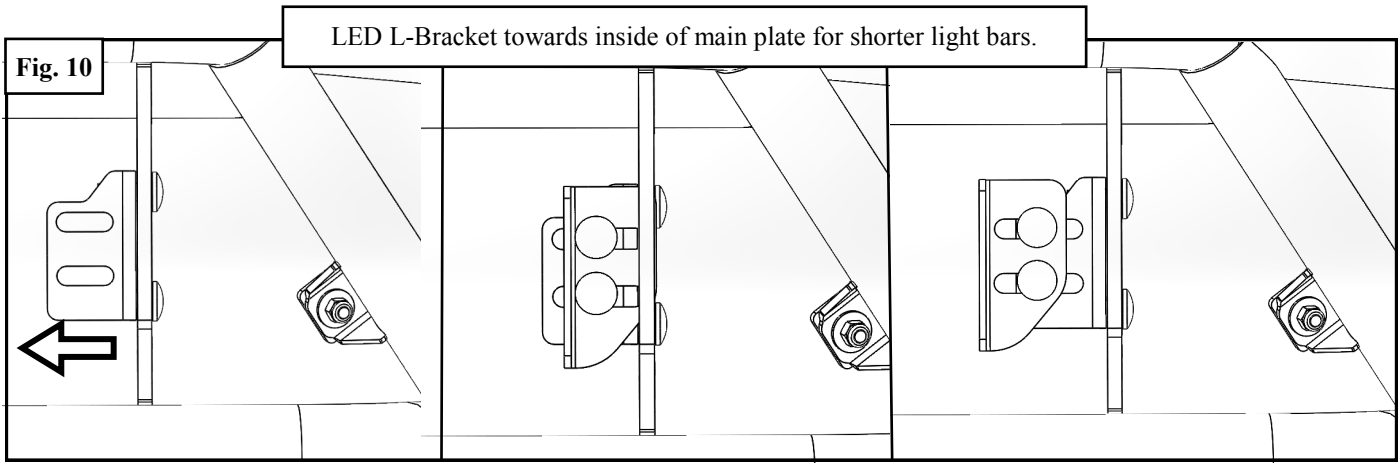
- Slide a M12 bolt plate (13) into the driver's side of the frame and loosely install support brackets (6 & 7) using the supplied M12 hardware (15-17). Repeat procedure on the passenger's side. See **Figure 7**.



- Loosely install frame brackets (4 & 5). **Note:** Use the supplied M12 hardware to fasten the frame brackets to the support brackets. Use the original hardware saved from step 3 to fasten the frame brackets to the frame. See **Figure 8**.

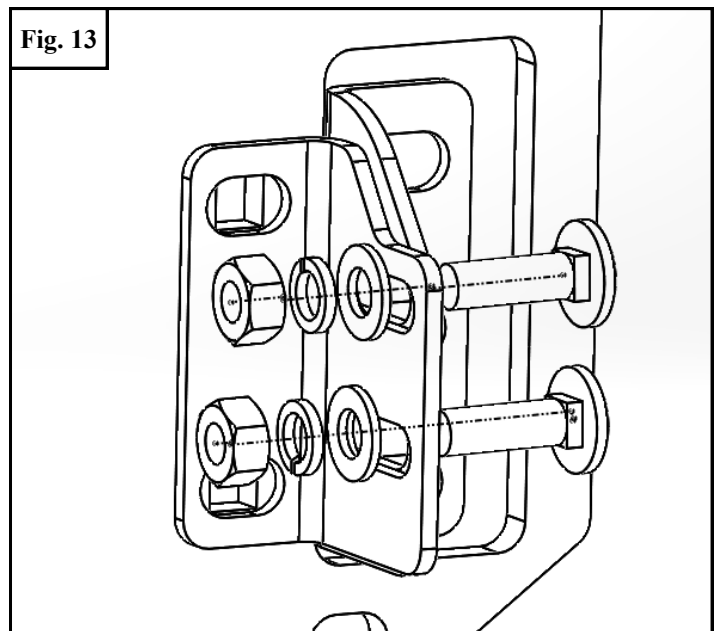
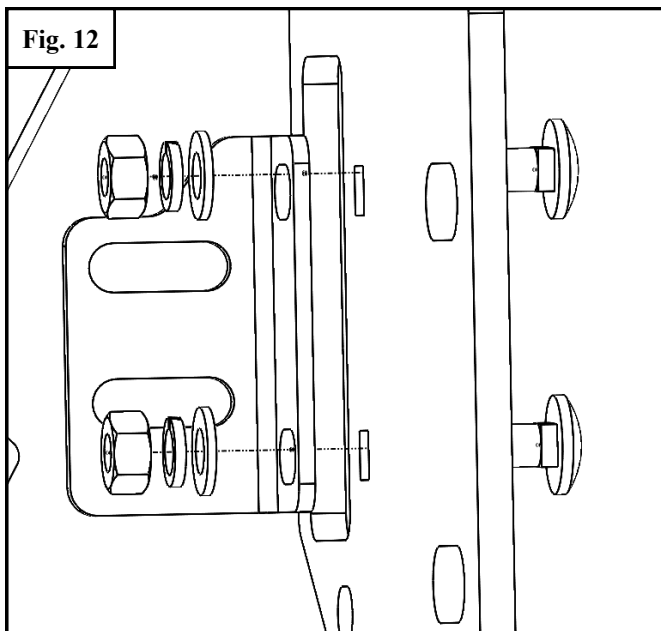
- Proceed to install center light bar brackets and light bar (s). The LED brackets (8-11) can be mounted in different configurations in order to have the necessary adjustment for various "30" inch light bar overall lengths. See **Figure 9-11**. **Note:** Lights sold separately.



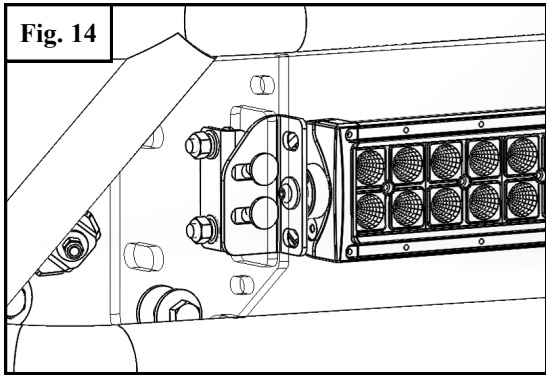


**Figure 11** is an example showing the LED brackets adjusted in for the shortest light bar configuration.

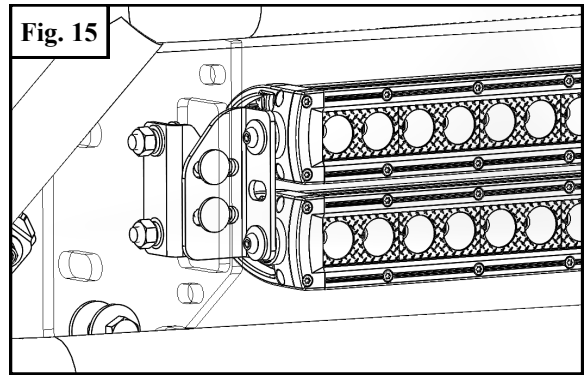
7. Using the supplied M8 hardware (18-21), loosely fasten LED L-Brackets (9 & 10) to main plate. See **Figure 12**.
8. Using the supplied M8 hardware (18-21), loosely fasten LED Slider Bracket (7 & 8) to LED L-Bracket. See **Figure 13**.



9. Using hardware included in the LED light bar hardware kit, fasten light bar to bracket according to **Figures 14 & 15**.
10. Position light bar as desired and tighten all M8 hardware to 15-18 ft-lbs.

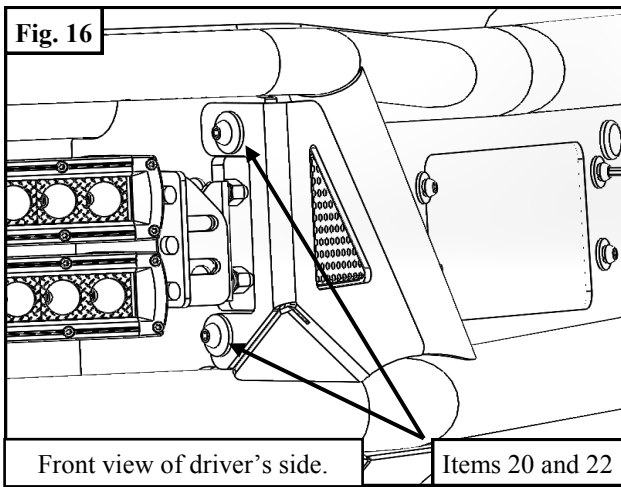


Single "Double Row" Light Bar Configuration



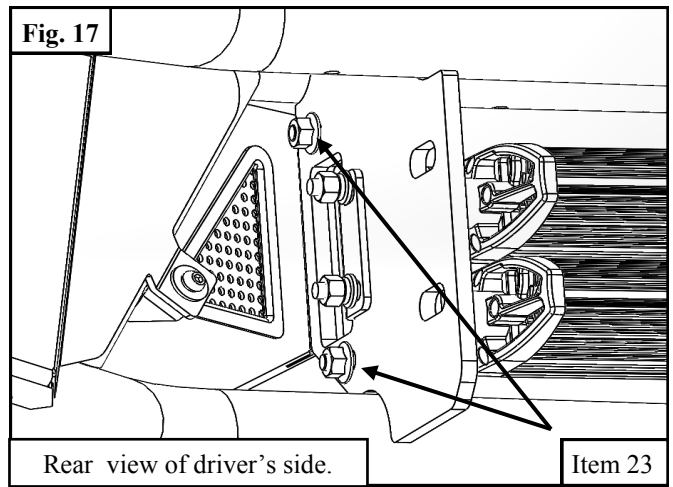
Double "Single Row" Light Bar Configuration

11. Position the meshed corner covers (3 & 4) as seen in **Figures 16 & 17**.



Front view of driver's side.

Items 20 and 22

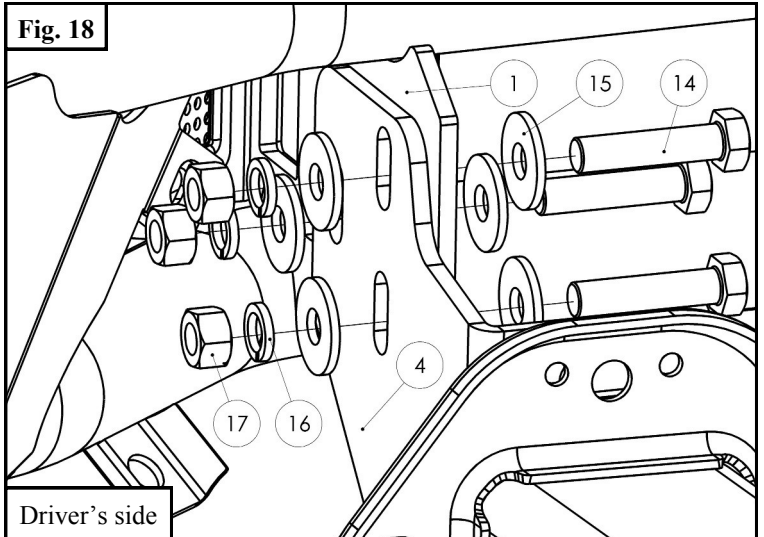


Rear view of driver's side.

Item 23

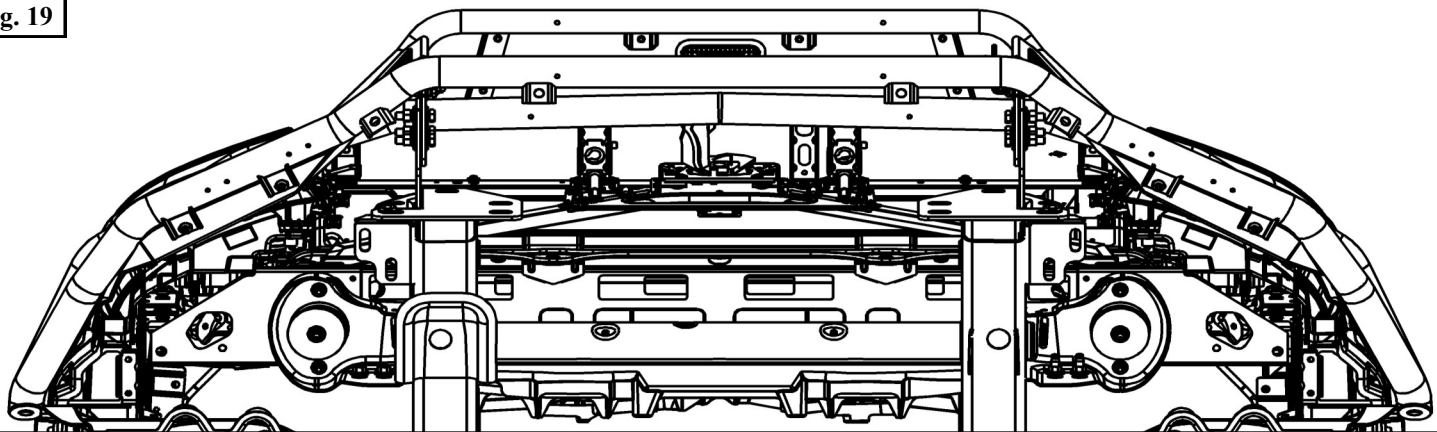
12. Using M8 serrated flange hex nuts (23), fasten corner cover into position. The serration on the nut should lock the nut in position allowing the installer to tighten button head bolts from the front using a 5mm Allen wrench. See **Figure 17**.

13. Using supplied M12 hardware (14-17), mount front bumper assembly to frame brackets according to **Figures 18 & 19**.



Driver's side

Fig. 19



14. Torque all M12 hardware to 50-55 ft-lbs.

15. **GMC Sierra Procedure** : Remove stock bumper

- a. Open the hood of the vehicle and remove the plastic cover at the front using a pry tool. See **Figure 1**.
- b. Remove the four bolts holding the grill in place and uninstall the grill. See **Figure 2**.
- c. Remove the braces on each side of the vehicle by removing the bolts indicated in **Figure 3**.
- d. Disconnect all electrical connections to the stock bumper.
- e. Remove the two bolts indicated in **Figure 4** on the driver's side of the vehicle. Repeat procedure on the passenger's side.
- f. Remove stock bumper. See **Figure 5**.
- g. Remove plastic trimming around fender. See **Figure 20-22**.
- h. Unclip filler panel between bumper and grille. (This piece will need to be trimmed. ) See **Figure 23-24**

Fig. 20



Fig. 21



Fig. 22



**CARE INSTRUCTIONS**

- REGULAR WAXING IS RECOMMENDED. DO NOT USE ANY TYPE OF POLISH OR WAX THAT MAY CONTAIN ABRASIVES.
- STAINLESS STEEL PRODUCTS CAN BE CLEANED WITH MILD SOAP AND WATER. STAINLESS STEEL POLISH SHOULD BE USED TO POLISH SMALL SCRATCHES.
- GLOSS BLACK FINISHES SHOULD BE CLEANED WITH MILD SOAP AND WATER.

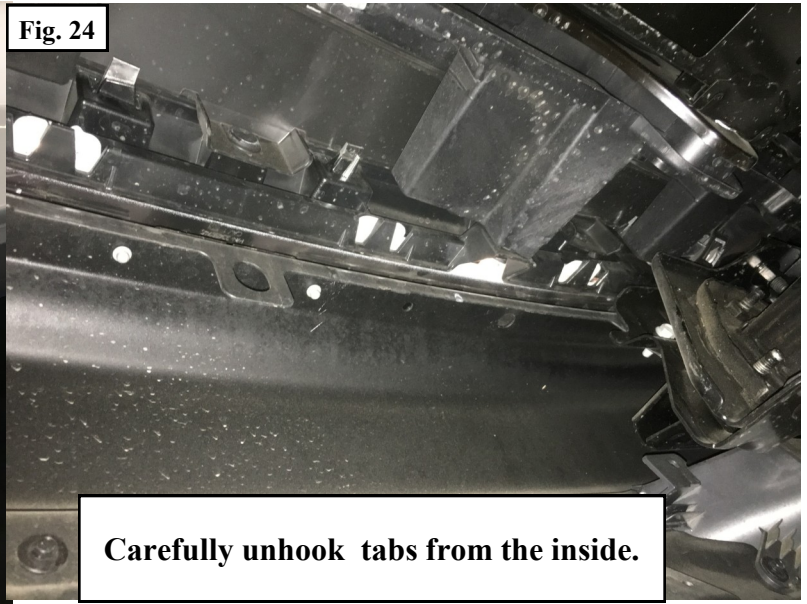


Westin Automotive Products, Inc.  
320 W. Covina Blvd  
San Dimas, Ca. 91773

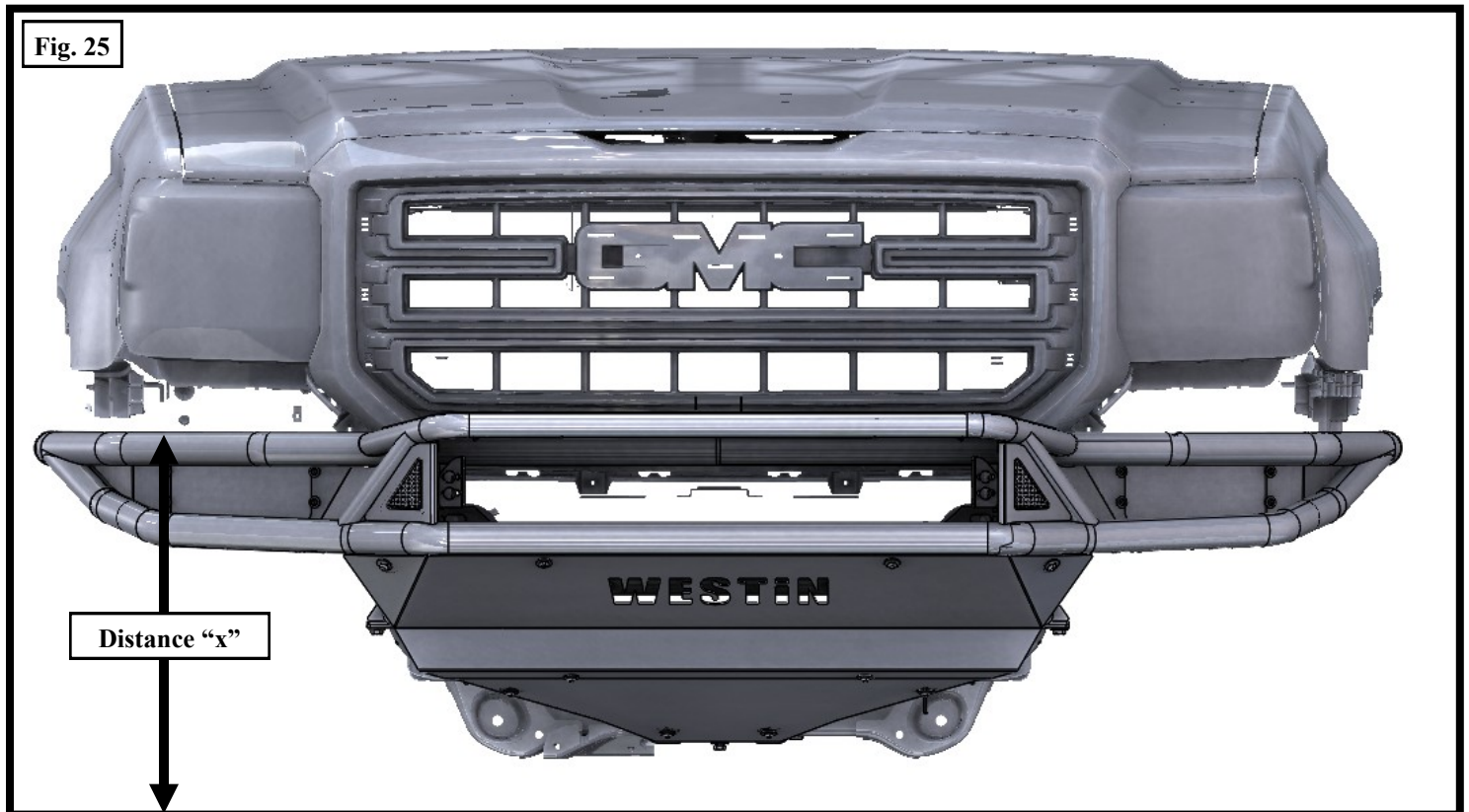
Thank you for choosing Westin products  
for additional installation assistance please call  
Customer Service (800) 793-7846

www.westinautomotive.com

DATE: 9/19/17

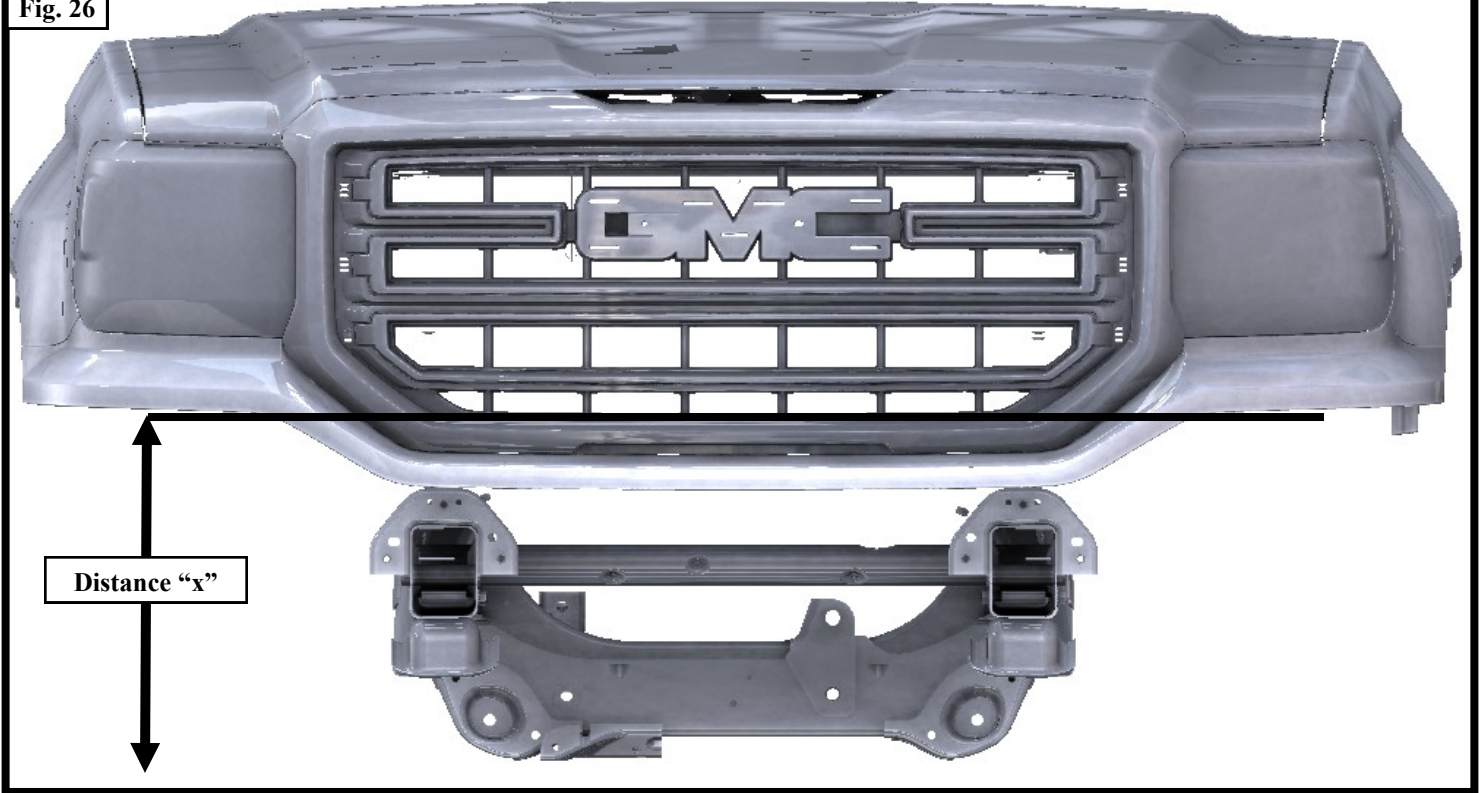


16. Without the filler panel on the truck, install Outlaw bumper according to steps described for Chevrolet Silverado and position as desired. See **Figure 25**.



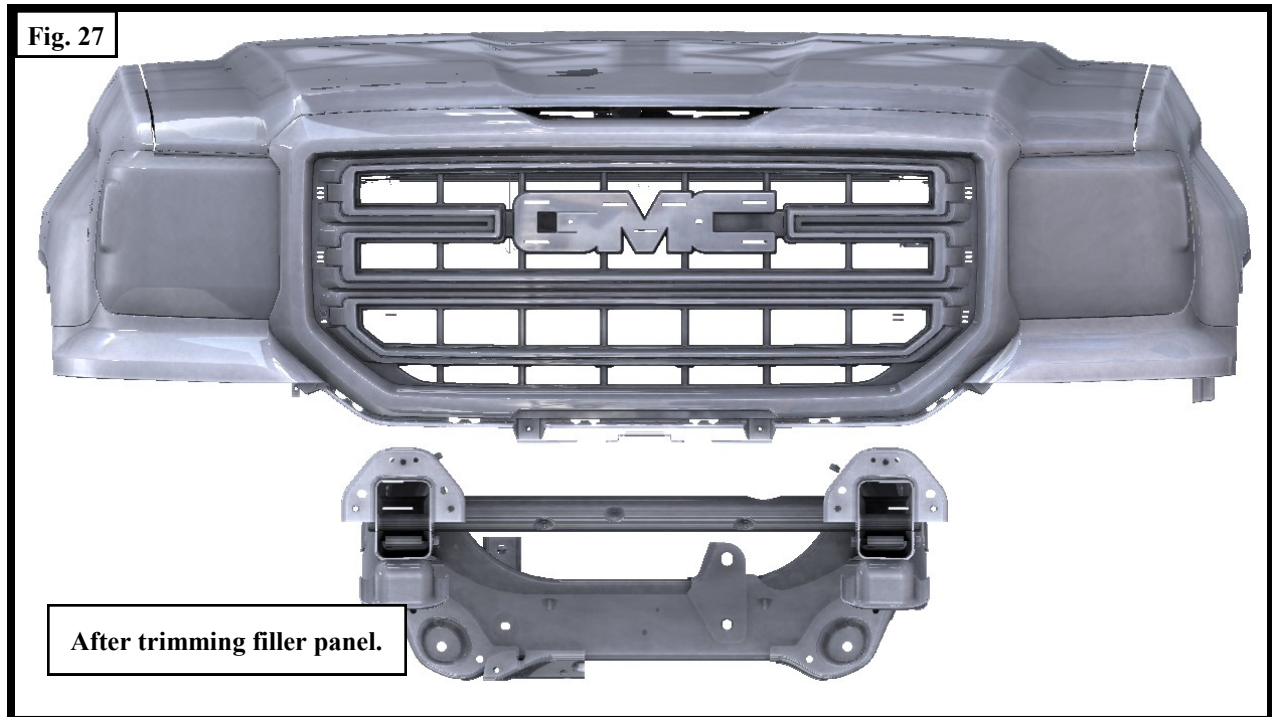
17. Making sure the bumper is aligned and position as desired, measure vertical distance from the ground (make sure is leveled) to the top of the bumper where filler panel needs to trimmed.

Fig. 26



17. Remove outlaw bumper and install filler panel back on the truck. Measure vertical distance “x” from the ground to the filler panel and mark with pen. Trim as necessary. See **Figure 26**.

Fig. 27





# Installation Complete





## WARNING



Failure to follow these instructions could lead to death, personal injury, and / or property damage.

### FASTENERS:

All Westin supplied fasteners must be utilized and installed in accordance with the installation instructions and apply torque to the specifications as defined. **DOUBLE CHECK ALL FASTENERS BEFORE INITIAL USE, AND PERIODICALLY IN THE FUTURE TO ENSURE PROPER FUNCTION AND SAFETY.**

### DRILLING:

Most Westin products do not require drilling for installation. If drilling is defined as required, use caution when drilling a vehicle. **FAILURE TO REVIEW AN AREA TO BE DRILLED MAY RESULT IN PERSONAL INJURY AND/OR INJURY TO OTHERS AS WELL AS VEHICLE DAMAGE.**

### EYE PROTECTION:

**ALWAYS WEAR SAFETY GLASSES OR GOGGLES DURING THE INSTALLATION PROCESS TO AVOID PERSONAL INJURY.**

### MAXIMUM TOWING/CARRYING CAPACITY:

The Westin Receiver Hitches will have a visible tow rating label affixed directly on the product. User should never exceed the vehicle manufacturers maximum tow and weight rating regardless of the capacity of the hitch. **FAILURE TO FOLLOW THESE GUIDELINES WILL VOID THE WESTIN WARRANTY AND MAY RESULT IN PERSONAL INJURY AND/OR INJURY TO OTHERS AS WELL AS VEHICLE DAMAGE.**



Westin Automotive Products, Inc.  
320 W. Covina Blvd  
San Dimas, Ca. 91773