



TENSION STRUT BALL JOINT KIT G80/G82 INSTALLATION INSTRUCTIONS

PART NUMBER D280-0030

APPLICATION:	2023	M2 (G87)
	2021-23	M3 Sedan & xDrive (G80)
	2021-23	M4 Coupe & xDrive (G82)
	2021-23	M4 Convertible & xDrive (G83)

PARTS LIST

Qty	Part #	Description
2	D282-0061	Cap
1	D282-0044	Cap Tool
4	D282-0062	Spacer
2	D283-0042	Balljoint/Holder Assy G80/G82
2	D281-0003	609 Loctite

Congratulations for being selective enough to use a Dinan Monoball Kit. We have spent many hours developing this kit to assure that you will receive maximum performance and durability with minimum difficulty in installation. Please take the time to read these instructions and call us if you have any difficulties during the installation.

DO NOT WORK ON VEHICLES SUPPORTED BY A JACK ONLY. USE SECURE JACK STANDS!

INSTALLATION:

1. Remove the front Tension-Struts per BMW recommended procedure 31 12 050. Press out the stock rubber bushing using a suitable tool. BMW procedures can be found @ bmwtechinfo.com
2. Clean out the bore with some soap and scotch-brite. The bore needs to be very clean and dry.

- Secure arm in vice and apply some Loctite 609 Retaining Compound (included in kit) to the outer bore of the Dinan monoball carrier. Use enough to cover most of the surface. See Figures 1 & 2.



Fig: 1



Fig: 2

4. See Figure 3 below. Slide the carrier into the bore in the arm with a slight turning motion to further spread the Loctite around. Slide the Balljoint Holder Assy into the chamfer side of the arm (see note below for xDrive vehicles).

Note – on xDrive vehicles, the control arm is curved as shown below. Please insert the Dinan balljoint holder from the direction shown, and align the notch towards the curved arm. This will permit maximum clearance to tighten the cap in the next step.

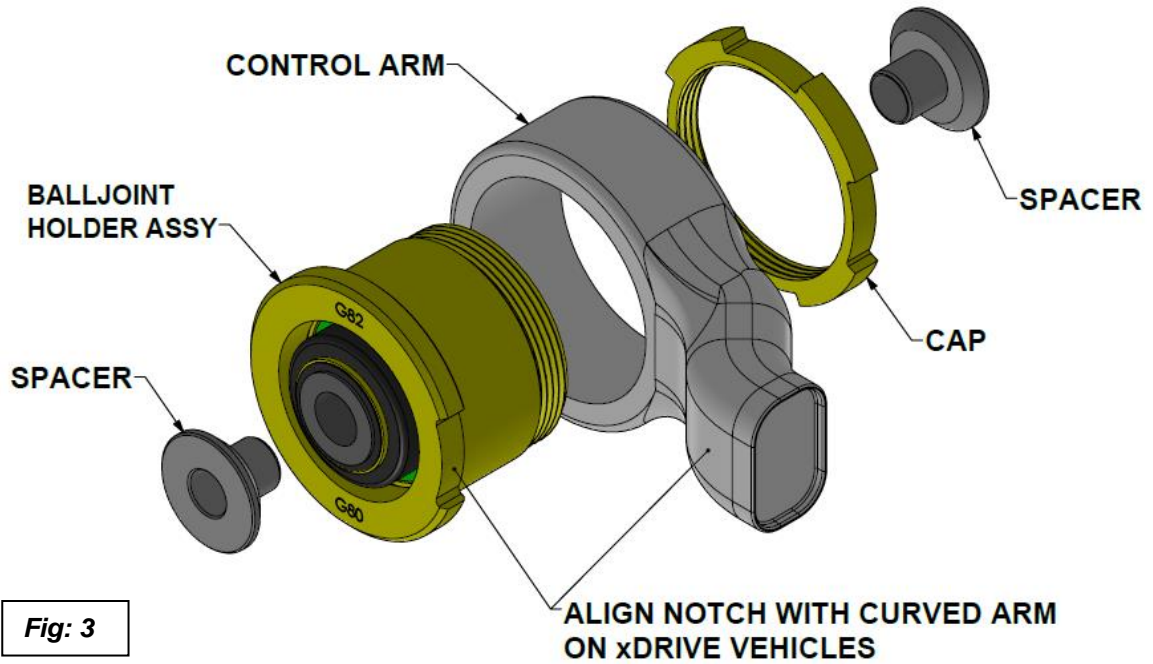

5. Install the Dinan retaining cap onto the arm. Put a small amount of Loctite on the internal threads of the cap and torque to 110 foot-pounds to secure the retaining cap. A special Dinan cap tool is included in every kit. This tool is used with a 1/2" torque drive. Set torque wrench to 110 foot-pounds and do not concern yourself with a conversion factor. See Figure 4.

Note – when tightening on xDrive vehicles, please ensure that the notch in the holder assembly remains aligned with the curved arm.



Fig: 4

6. Install the Dinan silver bearing spacers as shown.
7. Install the arms to the car using the stock bolts & nuts (replace as necessary).
8. Torque the bolts per BMW recommended procedure. NOTE: The monoball bolts must also be angle torqued per BMW specification!
9. Enjoy!