

**Detroit Speed**  
**2nd Generation Camaro/Firebird Mini-Tub Kit**  
**1970-1981 Camaro/Firebird**  
**P/N: 041222DS, 041223DS, 041226DS, 041227DS,**  
**041233DS, 041234DS, 041235DS & 041236DS**

The Detroit Speed Second Generation Camaro/Firebird Rear Mini-Tub Kit is designed to accommodate wider tire and wheel packages. It has been engineered for a precise fit and retains a stock appearance. The Mini-Tubs are wider than stock, stamped from 18-gauge steel, and are Made in the USA.



P/N: 041223DS Shown

Item	Component	Quantity
1	Detroit Speed Mini-Tubs- 1970-1981 Camaro/Firebird (Optional)	2
2	Rear Upper Shock Crossmember	1
3	Rear Upper Shock Crossmember End Cap	2
4	Upper & Lower Shock Mount Bolt (1/2"-20 x 3" L)	4
5	Upper & Lower Shock Mount Nylock Nut (1/2"-20)	4
6	Upper & Lower Shock Mount Washer (1/2" SAE)	4
7	Upper Shock Mount Bushing (3/4" OD x 1/2"ID x 3/4" L)	2
8	Lower Shock Mount Bushing (3/4" OD x 1/2"ID x 1/4" L)	2

9	Detroit Speed Mini-Tub Forward Flange	2
10	Detroit Speed Mini-Tub Rear Flange	2
11	Offset Shackle Set	1
12	Delrin Leaf Spring Bushing Set- Rear Bushings	1
13	Adjustable Leaf Spring Pad	2
14	1/2" U-Bolt Kit	1
15	Lower Shock Plate- Right Hand	1
16	Lower Shock Plate- Left Hand	1
17	Frame Rail Closeout	2
18	Leaf Spring Pocket Mount	2
19	Leaf Spring Pocket Bolt (3/8"-16x1" L)	6
20	Leaf Spring Pocket Lock Washer (3/8")	6
21	Leaf Spring Pocket Flat Washer (3/8")	6
22	Rear Seat Belt Bolt Mount	2
23	J-Clip	4
24	Template	8
25	Detroit Speed Rear Leaf Spring (2" or 3" Drop)	2
26	Mini-Tub Shock	2
27	Instructions	1

## INTRODUCTION

Congratulations on your purchase of the Detroit Speed Second Generation Camaro/Firebird Rear Mini-Tub Kit/Leaf Spring Kit. Please read the entire set of instructions and fully understand all the steps involved before beginning the project.

**NOTE:** All work should be performed by a qualified welder and technician.

**NOTE:** The DSE Mini-Tubs were designed to OEM sheet metal, therefore any aftermarket restoration sheet metal may require additional body work to fit to the DSE Mini-Tubs.

**NOTE:** There is an installation video available through the Detroit Speed website in the tech/install video section shown here:

<https://www.detroitsspeed.com/1970-81-camaro-install-videos>.

### I. PREPARE THE VEHICLE

1. Raise the vehicle a few feet off the ground so the interior, trunk, and the underside of the vehicle are accessible. Ensure the vehicle is level and well supported.
2. Disconnect the battery cables.
3. Remove the gas tank and fuel lines. **NOTE:** Make sure to eliminate all the fuel vapors from the work area before continuing.
4. Remove the rear suspension and axle.

5. Remove the seats, carpet, carpet padding, rear interior quarter trim panels, and package tray. Any other interior panels, headliner, door panels, etc., should be removed or masked well to protect them from grinding and welding sparks.
6. If you have purchased the complete DSE Mini-Tub Kit, continue to the next step. If you have purchased the DSE Mini-Tub Leaf Spring Kit, skip to **Section IV** on page 11.

## II. REMOVE STOCK INNER WHEELWELL

1. With the interior removed, mark the cut line to remove the seat back support. Drill out the spot welds and cut at the cut line. Remove the remaining material. On the next page, Figure 1 shows the cut line and the location of the spot welds. Figure 2 shows the piece cutout and removed.



Figure 1 - Seat Support Cut Line



Figure 2 - Seat Support Removed

2. Cut out the Front and Rear Mini-Tub Inner Wheelwell Templates that are provided for the floor and trunk pan.
3. Position the Inner Wheelwell Front Template inside the vehicle and center punch the hole for the new seat belt bolt hole, as shown in Figure 3. **NOTE:** This step is only for 1970-75 Camaro/Firebird.



Figure 3 - Inner Wheelwell Front Template with Tab

4. Remove the Inner Wheelwell Front Template and remove the tab used in the previous step.



5. Replace the template and trace around the wheelwell templates to form the cut line. Perform this step for both the rear seat floor pan (Figure 4) and the trunk floor pan (Figure 5).



Figure 4 - Inner Wheelwell Front Template



Figure 5 - Inner Wheelwell Rear Template

6. Extend the cut line upward along the seat back using 2" tape, as shown in Figure 6. This will connect the front and rear wheelwell templates.



Figure 6 - Cut Line Extension Using 2" Tape

7. Identify the spot welds that connect the inner and outer wheeltubs and drill out the spot welds.
8. Remove the original inner wheel tub by using a 3/32" 3M cut off wheel in a die grinder. **NOTE:** This is only a rough cut. Make sure all appropriate safety attire is worn and all equipment is in proper working condition.
9. Measure 2-3/4" up from the bottom of the rocker panel pinch flange and mark with a line. Extend the forward edge of the line upward, as shown in Figure 7 on the next page, to the new wheel tub opening. Remove the overlapped portion of the marked area.



Figure 7 - Marking Tab for Removal

10. Cut the floor pan and trunk pan along the marked lines and 2" tape, as shown in Figure 8 and 9 to allow proper clearance for the Detroit Speed Mini-Tub.

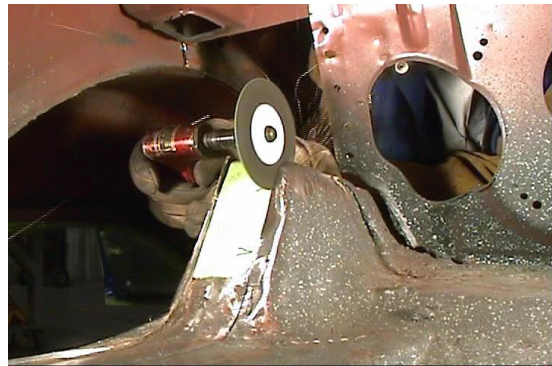
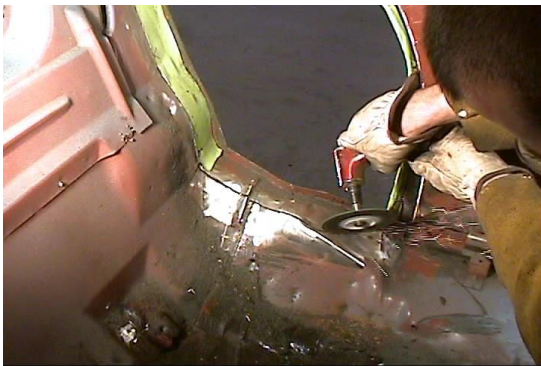

Figures 8 and 9 - Metal Removal for Clearance of Detroit Speed Mini Tubs

11. Clean and de-burr the flange between the inner and outer wheel tubs.

### III. INSTALL DETROIT SPEED MINI TUB

1. Test fit the new Detroit Speed Mini-Tub. It is a good idea to clamp the tub in place using locking pliers and/or self-tapping sheet metal screws.
2. Mark 1/4" below the lower edge of the Detroit Speed Mini-Tub on the frame rail. This will be used for locating the new wheel tub flange along the frame rail.
3. Mark the wheel tub flanges and templates at the same location on the wheelwell opening to allow for proper flange to template alignment, as shown in Figure 10



Figure 10 - Front Flange Alignment



- Transfer the bend profile from the supplied Inner Wheelwell Front and Rear Templates to the supplied front and rear flanges accordingly. Figure 11 and Figure 12 show the respective template to flange layout. **NOTE:** The templates are provided as a general shape. Bend the flanges to fit your car and your specific cut line. This should be done for both the front and the rear flanges.



Figure 11 - Front Template Bend Profile



Figure 12 - Rear Template Bend Profile

- Mark the floor pan to flange profile on the flange from the top side of the floor pan as shown in Figure 13. Remove the excess material from the flange. Perform this step for both the front and rear flanges.



Figure 13 - Marking Front Template to Floor Pan Profile

- Tack weld the front and rear flanges to the body as shown in Figure 14.



Figure 14 - Tack Weld Tub Flanges

7. Test Fit the Detroit Speed Mini-Tub to check the tub to flange fitment as shown in Figure 15. Make any adjustments to the flanges if needed.



Figure 15 - Test Fit Detroit Speed Mini-Tub

8. Mark along the inside of the floor pan and the trunk pan onto the Detroit Speed Mini-Tub. **NOTE:** This line will be used for reference when drilling the holes for spot welding.
9. Remove the Detroit Speed Mini-Tub from the vehicle and finish welding the flanges to the body.
10. Make marks 1-3/4" apart, as shown in Figure 16, between the reference line and the outer edge of the Detroit Speed Mini-Tub. Repeat this step on the flange between the inner and outer wheel tubs.

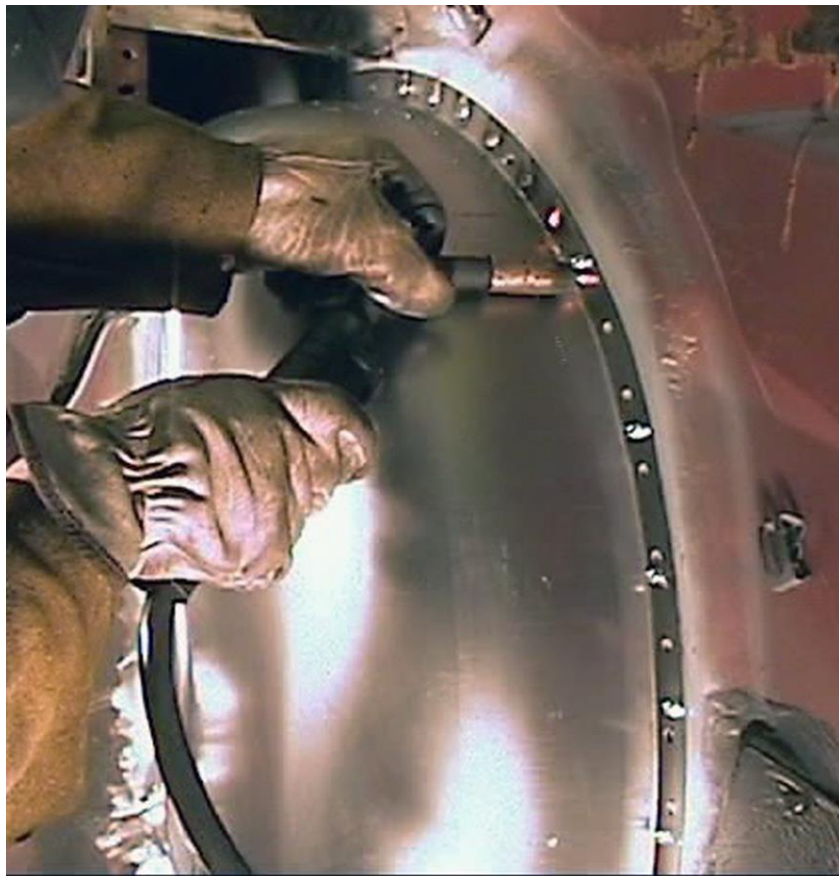

Figure 16 - Mark Tub Mounting Surfaces

11. Drill a series of 9/32" holes in the previously marked locations for the spot welds. A drill bit, Uni-Bit, or sheet metal punch can be used for this process.
12. Reinstall the Detroit Speed Mini-Tub and secure it with sheet metal screws and/or locking clamps. **NOTE:** It is a good idea to spray weld through primer on all surfaces that will be welded to prevent future rust formation.



13. Plug weld all of the holes as shown in Figure 17. Remove the sheet metal screws, if used, and plug weld the holes.



**Figure 17 – Plug Weld**

14. Weld the Detroit Speed Mini-Tub to the body side flanges along the bottom edge of the tub as shown in Figure 18.

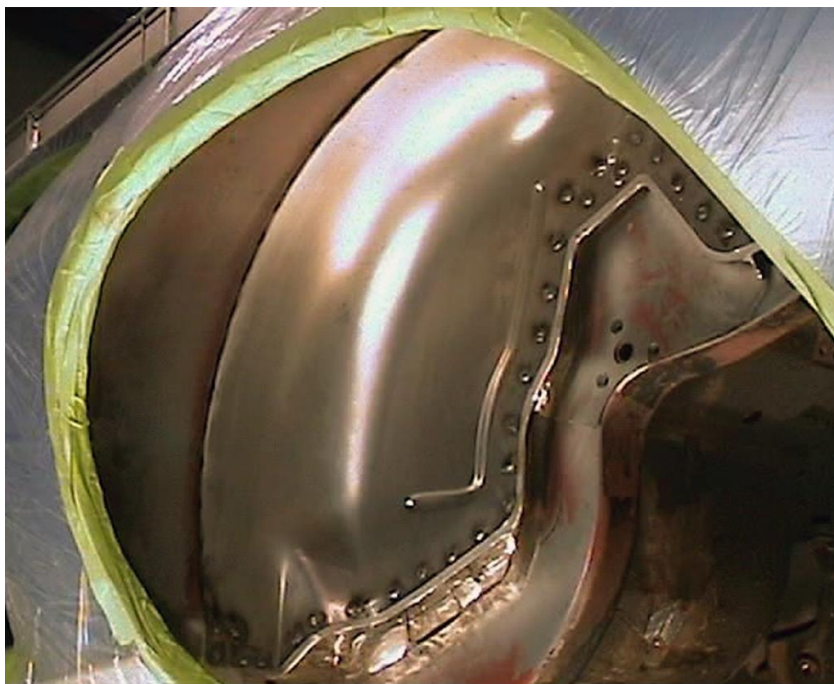

**Figure 18 – Weld Mini-Tub to Side Flanges**



15. Grind and smooth the spot welds after the welding is complete as shown in Figure 19.



Figure 19 - Smooth Spot Welds

16. Bend the outer wheel tub overlap flat against the Detroit Speed Mini-Tub and spot weld it in place, as shown in Figure 20.



Figure 20 - Wheel Tub Overlap

17. Lay out the new seat back bracket on 18-gauge sheet metal as shown in Figure 21.



Figure 21 - Seat Back Bracket Panel

18. Clamp the seat back bracket in place and spot weld it to the new Detroit Speed Mini-Tub and seat back as shown in Figure 22.



Figure 22 - Seat Back Bracket Installed



#### IV. INSTALL UPPER SHOCK CROSSMEMBER

1. Mark the centerline of the upper shock crossmember.
2. Slip the upper shock crossmember end caps on to the upper shock crossmember. **NOTE:** Do not weld the end caps at this time.
3. Measure from the front edge of the rear leaf spring eye in the frame rail 28.0" forward. Mark the frame rail at this location.
4. Clamp the upper shock crossmember in place using the alignment marks from the previous step. **NOTE:** Later model year Camaro/Firebird frame rail profile may be different. The upper shock crossmember end caps may need to be bent to follow the frame rail profile.
5. Position the centerline of the upper shock crossmember in the middle of the frame rails. Once the upper shock crossmember is positioned correctly with the upper shock mount tabs pointing to the rear of the vehicle, tack weld the upper shock crossmember to the end caps. **NOTE:** Do not completely weld the end caps at this time.
6. Remove the upper shock crossmember from the vehicle. The end caps will be finish welded to the upper shock crossmember later after the rear shocks are mocked up in the vehicle.

#### V. MODIFY LEAF SPRING POCKET MOUNT AND FRAME RAIL

1. Cut out the provided templates labeled: Exterior Leaf Spring Pocket Mount Template A, Exterior Leaf Spring Pocket Mount Template B, Outboard Side Frame Rail Template, Inboard Side Frame Rail Template, and Interior Leaf Spring Pocket Mount Template.
2. Position the Exterior Leaf Spring Pocket Templates A and B, as shown in Figures 1 and 2, on the underside of the floor pan. Mark the cut lines from the template on the floor pan. Use the bolt holes in the frame rail to help locate the templates.



Figure 1 - Leaf Spring Pocket Template - A



Figure 2 - Leaf Spring Pocket Template - B

3. Position the Inboard and Outboard Frame Rail Templates, as shown in Figures 3 and 4 on the next page, on the frame rail using the bolt holes in the frame rail to locate the templates. The templates have letters that will help locate adjoining templates. Use tape to secure the templates to the frame rail.





Figure 3 - Inboard Frame Rail Template



Figure 4 - Outboard Frame Rail Template

4. Mark the lines along the template for the cut lines on the frame rail. The cut lines will be used to clearance the frame rail for the leaf springs.
5. Center punch the center of the new hole for the relocated leaf spring pocket bolt.
6. Cut the previously marked lines using a cutoff wheel as shown in Figure 5.  
**NOTE:** As you cut into the frame rail for the Frame Rail Closeout, continue cutting into the floor to allow the closeout to properly set into the frame rail.

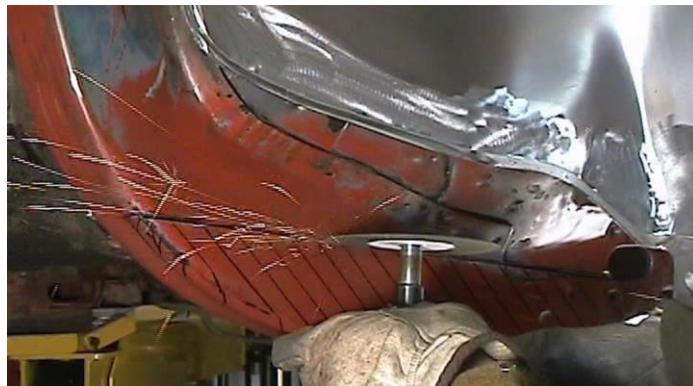

Figure 5 - Cutting the Frame Rail

7. Position the Interior Leaf Spring Pocket Mount Template. The rearward most edge of the template will line up with the hole cut from the previous step. Mark the curved line of the template on the floor. Using tape, extend the inward line of the template to form a triangular shape on the floor. Figure 6 shows the installed template and tape line.

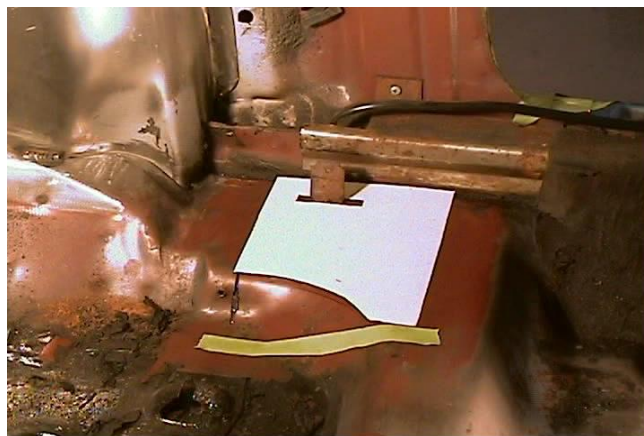

Figure 6 - Interior Leaf Spring Pocket Template

- Cut the previously marked lines using a cutoff wheel as shown in Figure 7.

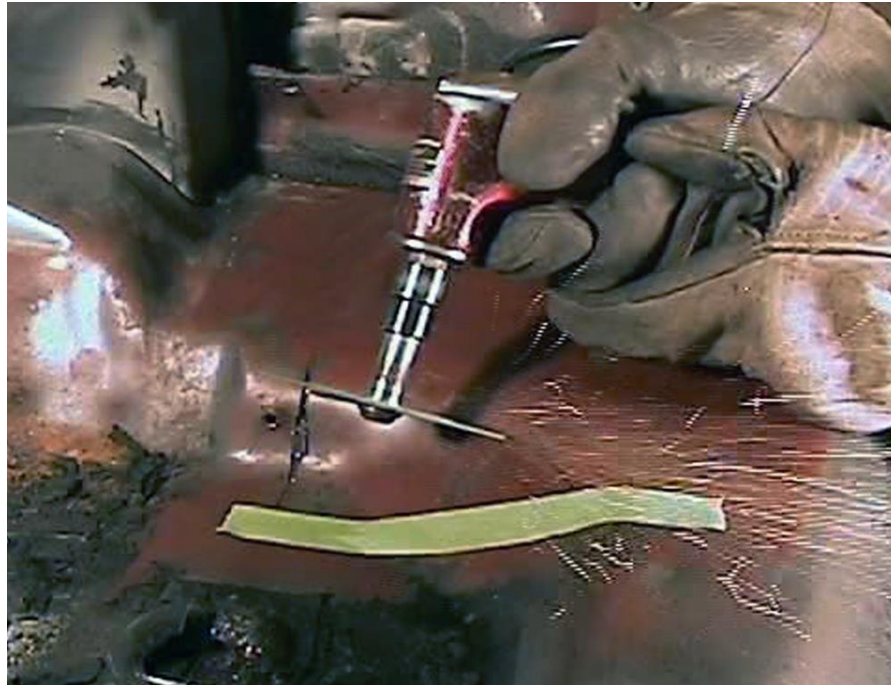

Figure 7 - Cutting for the Leaf Spring Pocket

- Drill the new hole for the leaf spring pocket bolt and insert the provided J-clips.
- Temporarily install the new leaf spring pocket mount using the provided 3/8"-16 x 1" L Hex Head bolts along with the 3/8" lock and flat washers, as shown in Figure 8, and secure it with the two original leaf spring pocket bolts.



Figure 8 - Leaf Spring Pocket Mount

- Position the frame rail closeout in place and mark the lines for the excess material to be removed.
- Remove the frame rail panel, and trim off the excess material.



13. Reinstall the frame rail panel, and spot weld it in place as shown in Figure 9. After any final fitment is performed, fully weld the panel in place.

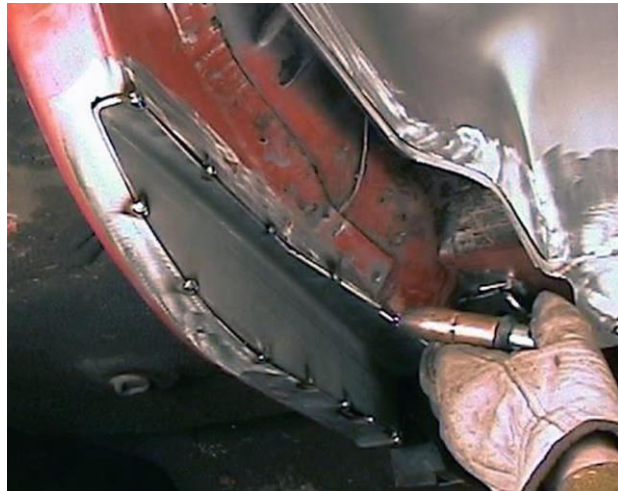

Figure 9 - Frame Rail Closeout

14. Reinstall and weld the new leaf spring pocket mount in place as shown in Figure 10.



Figure 10 - Welding the Leaf Spring Pocket

#### VI. INSTALL SEAT BELT BOLT MOUNT (1970-75 Camaro/Firebird only)

1. Drill a 1/2" hole for the rear seat belt bolt in the interior floor pan at the location marked in Step 3 on page 3. See Figure 1.



Figure 1 - Seat Belt Bolt



2. Position the seat belt bolt mount over the hole from the previous step and mark around the outer perimeter of the mount.
3. Remove the seat belt bolt mount and center punch four holes 90° apart from each other between the outer perimeter and the center hole.
4. Drill four 9/32" holes in the previously marked locations as shown in Figure 2.



Figure 2 - Seat Belt Mount

5. Bolt the rear seat belt bolt mount to the underside of the floor pan as shown in Figure 3 and plug weld the four holes. Remove the bolt and grind the welds smooth. **NOTE:** Make sure not to weld the bolt in place.

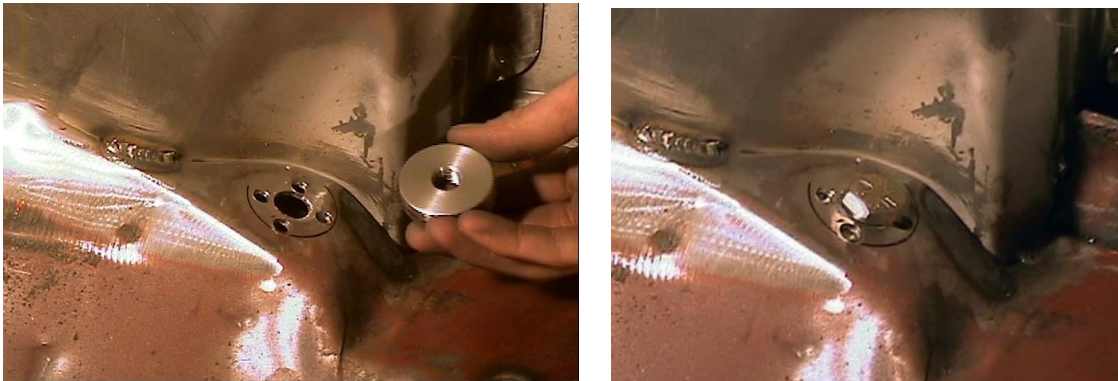

Figure 3 - Seat Belt Bolt Mount

6. Weld the rear seat belt bolt mount to the underside of the floor as shown in Figure 4. **NOTE:** Make sure to weld as much of the seat belt bolt perimeter as possible.



Figure 4 - Weld Seat Belt Mount

## VII. REPEAT

1. Repeat sections I thru VI for the other wheel tub on 1970-75 Camaro/Firebirds, or sections I thru V for 1976-81 Camaro/Firebirds.
2. Paint all bare metal to prevent the formation of rust.

## VIII. REAR SEAT MODIFICATION

1. Remove the rear seat cover and padding. Modify the bottom of the seat frame to clear the Detroit Speed Mini-Tubs, as shown in Figure 1.



Figure 1 - Rear Seat Frame Modification

2. Narrow the back of the rear seat by 2" on either side as shown in Figure 2.



Figure 2 - Narrowed Rear Seat Frame

3. Reinstall the rear seat padding and seat cover.

4. Modify the rear interior quarter trim panels, as shown in Figure 3, by adding 2" of material to allow clearance for the DSE Mini-Tubs.



Figure 3 - Modified Interior Quarter Trim Panels

#### IX. INSTALLING THE DELRIN REAR LEAF SPRING BUSHINGS

1. After removing your stock shackles and pressing out your stock bushings (if applicable), install the Delrin leaf spring bushings. Make sure that the bushings are oriented in the shackles as follows, this will insure easy access for greasing.
  - The upper, two-piece bushings should be installed with the grease fittings facing toward the inside and front of the vehicle.
  - The lower, one-piece bushings should be installed with the grease fittings facing down and toward the outside of the vehicle.
2. The correct bushing configuration can be seen in Figure 1. **NOTE:** Figure 1 shows the passenger side shackle as viewed from the front of the shackle.

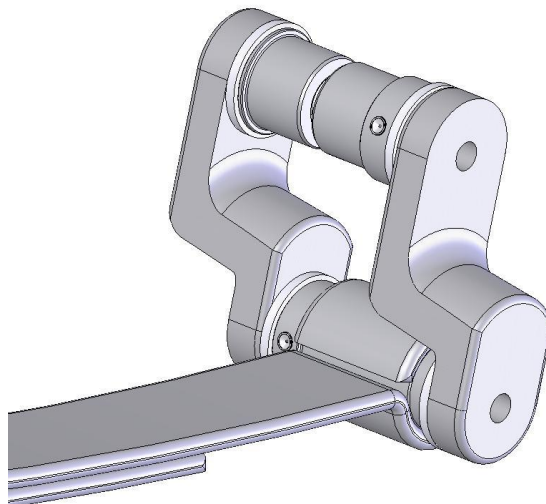
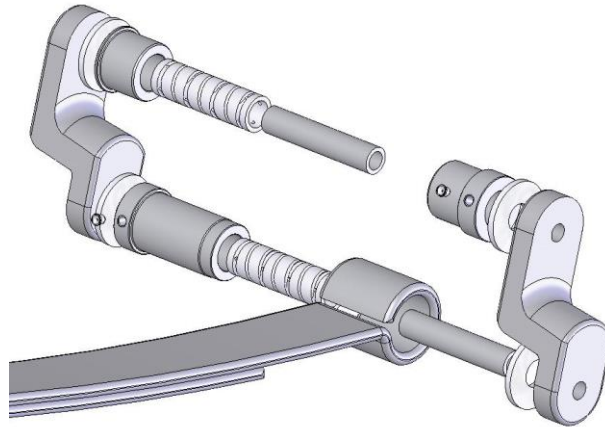

Figure 1 - Assembled View of Offset Shackle with Bushings



3. This configuration is correct for standard and offset shackles. The included Delrin™ washers should be installed between the bushing and the shackle at each contact point as seen in Figure 2.

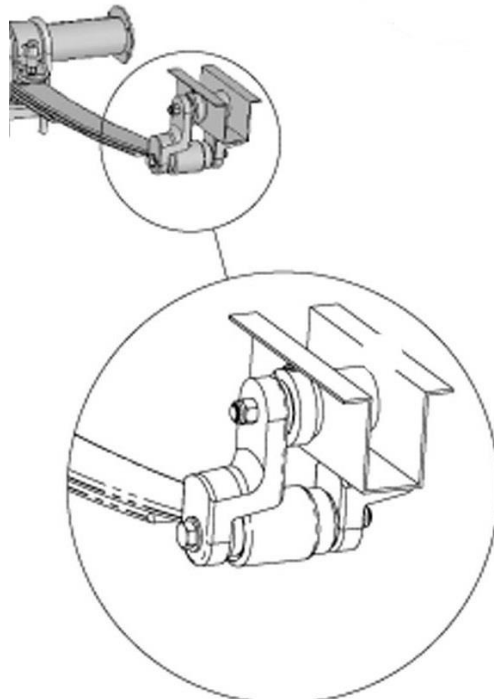

**Figure 2 - Exploded View of Offset Shackle with Bushings**

4. Installing the bushings can be made easier by pre-lubricating the bushings before pressing them into the springs and shackle mounts. Use the provided 609 Loctite® between the aluminum bushing and the bore in the frame for the bushing. After installation, the bushings should be lubricated thoroughly and checked for adequate lubrication from time to time.

## **X. INSTALLING THE OFFSET SHACKLES**

1. Install the offset shackles so that the offset portion of the shackle is inboard of the frame rail as shown in Figure 1. Do not torque at this time. Once the rear suspension is loaded with the weight of the vehicle, then torque the rear shackle bolts to 90 ft-lbs.



**Figure 1 - Offset Shackles**

## XI. INSTALLING THE LEAF SPRINGS

1. Install the leaf springs and leaf spring bushing spacers into the vehicle using the new leaf spring front pocket mount and the rear offset shackles. **NOTE:** The leaf springs should be installed so that the bushing spacers offset the leaf springs inboard to maximize tire clearance. Do not torque at this time.

## XII. INSTALLING THE ADJUSTABLE LEAF SPRING PADS

1. It will be necessary to remove the factory leaf spring pads from your axle housing tubes by cutting and grinding the axle tubes smooth. Set the rear axle on top of the leaf springs. Install the Detroit Speed adjustable leaf spring pads on the axle housing and lightly clamp.
2. Center the housing at the new leaf spring location and adjust the pinion angle at ride height. It is recommended that the adjustable leaf spring pads be clamped securely in position once the pinion angle and spring widths are set. **NOTE:** Failure to draw the bolts down evenly will cause permanent damage to the spring pads. Detroit Speed recommends a pinion angle of  $-3^{\circ}$  to  $-4^{\circ}$  down towards the ground.
3. Remove the leaf springs and permanently attach the pads by **welding** the lower spring pad bases to the axle tubes. Use care when welding, excessive heat can distort the axle tubes. See Figure 1. **NOTE:** The spring pads **must be welded** to the axle tube before driving the vehicle.

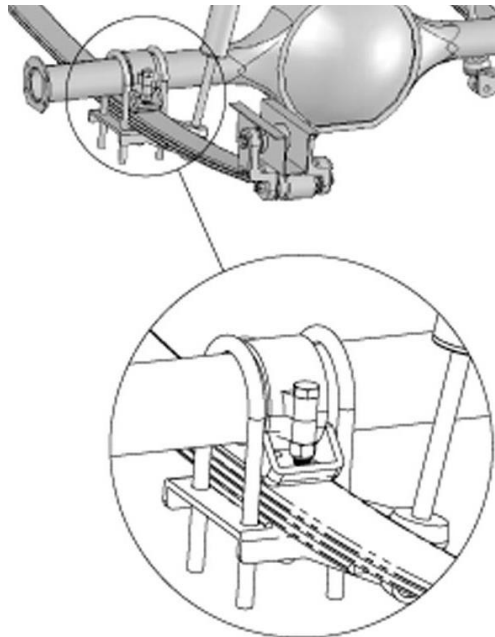

Figure 1 – Adjustable Leaf Spring Pads

## XIII. INSTALLING THE LOWER SHOCK PLATES

1. Install the lower shock plates to the vehicle using the provided 1/2"-20 U-Bolts as shown in Figure 1 on the next page. For a 1970-81 Camaro/Firebird, you will have a left and a right-hand shock plate as the driver and passenger side shocks are on the back side of the rear axle, both inboard of the leaf springs. Part number 040301RDS will go on the driver's side and part number 040301LDS will go on the passenger's side.

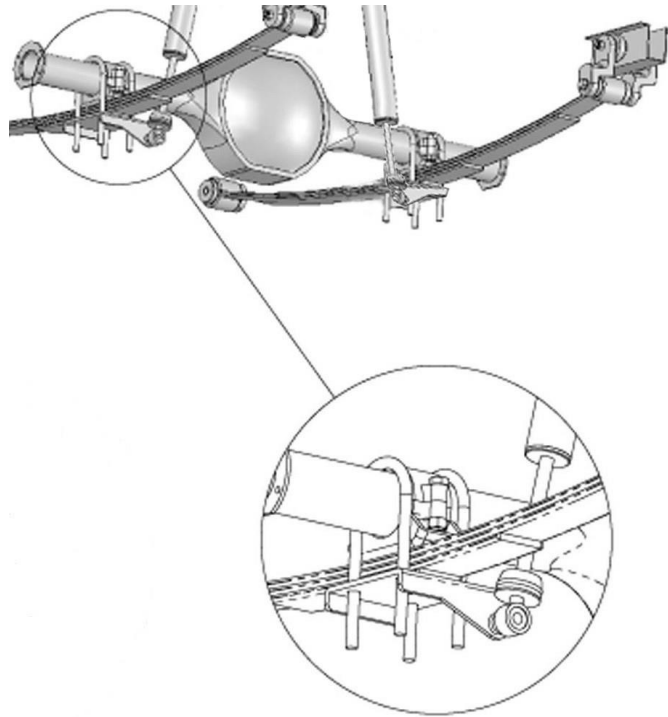

Figure 1 - Lower Shock Plates

#### XIV. INSTALLING THE MINI-TUB SHOCKS

1. Position the rear upper shock crossmember back into the vehicle. Clamp the upper shock crossmember back in place using the framerail alignment marks from Section IV.
2. Install the Detroit Speed Mini-Tub shocks with the body side up to the upper shock mounts using the provided 1/2"-20 x 3" L hex head bolts and upper shock mount bushing. **NOTE:** There is an upper and lower shock mount bushing so make sure you have the correct one. The longer bushing is for the upper shock mount and the shorter bushing is for the lower shock mount.
3. Place the upper shock mount bushing on the bolt and install it through the inside of the upper shock crossmember. Place the shock into the upper shock crossmember and install the bolt. Tighten the bolt with the provided 1/2"-20 Nylock nuts and washers.
4. Attach the Mini-Tub shocks to the lower shock plates using the provided 1/2"-20 x 3" L hex head bolts. Install the bolt with the lower shock mount bushing through the lower shock eyelet. **NOTE:** There is an upper and lower shock mount bushing so make sure you have the correct one. The longer bushing is for the upper shock mount and the shorter bushing is for the lower shock mount.
5. Install the bolt through the lower shock plate and tighten with the provided 1/2"-20 Nylock nut and washer. Maintain shock tube to axle tube clearance during suspension travel. **NOTE:** If the shock body is interfering with the upper shock crossmember, rotate the tube in the end caps until the shock body has clearance during suspension travel. You will need to remove the tack welds, rotate the tube in the end caps and re-tack weld the tube to the end caps to re-check the shock body clearance.



6. Once you have shock clearance, remove the upper shock crossmember from the vehicle and finish welding the end caps as shown in Figure 1.



**Figure 1 - Weld End Caps to Crossmember**

7. Re-install the upper shock crossmember and weld it in place as shown in Fig. 2.

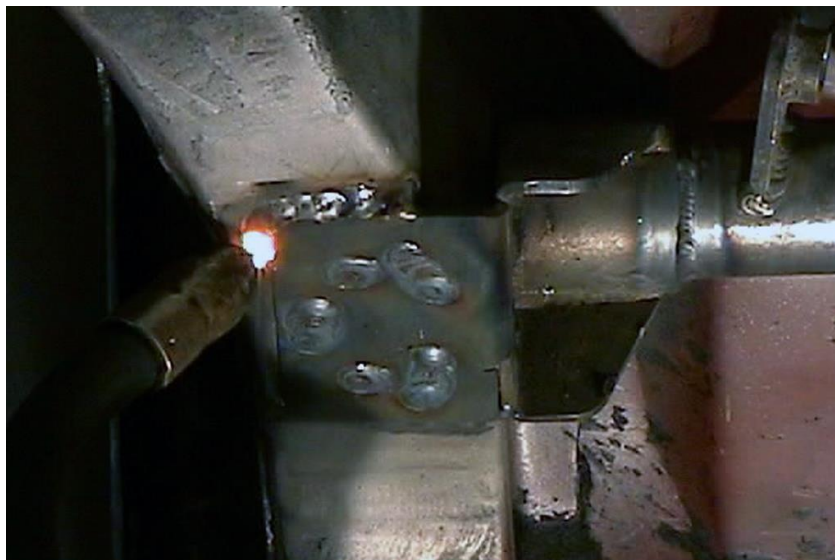

**Figure 2 - Weld Crossmember**

8. With the weight of the vehicle on the rear axle, a reference length of the rear shocks at ride height should be 15" to 15-1/2" from eyelet to eyelet with the Detroit Speed mini-tub shocks.

## XV. FINAL ASSEMBLY

1. Once the rear suspension is loaded with the weight of the vehicle, then torque the front leaf spring eye bolt and rear shackle bolts to 90 ft-lbs.
2. If the kit was purchased without the leaf springs the rubber front bushing must be pressed out. The leaf spring front spacer must be installed, and the bushing pressed back in place with the spacer on the outboard side of the leaf spring. This will provide the maximum tire to leaf spring clearance.
3. A stainless-steel narrowed gas tank is available from Detroit Speed to fit between the new offset leaf spring locations.
4. Reinstall the package tray, rear interior quarter trim panels, carpet padding, carpet, seats, gas tank, rear suspension, and any additional interior panels that were removed for the installation process.
5. Check all rear clearances before driving the vehicle and make sure all hardware is tightened and has been installed with the correct torque settings.
6. Enjoy your new rear suspension!

If you have any questions before or during the installation of this product, please contact Detroit Speed at [tech@detroitsspeed.com](mailto:tech@detroitsspeed.com) or 704.662.3272