

INSTALLATION INSTRUCTIONS



APPLICATION: Ford F-250/350/450/550HD 2008-2021, Dodge/Ram
1500 2002-2018, 1500 Classic 2019-2021, 2500/3500 2003-2021

PART NUMBER: 57-8003, 57-8005, 57-8033, 57-8035

CONTENT			
ITEM	QUANTITY	DESCRIPTION	TOOLS NEEDED
1	1	HEADACHE RACK	18MM SOCKET
2,3	2	MOUNTING BRACKETS (2) DRIVERS SIDE, (3) PASSENGER SIDE	18MM WRENCH
4	8	M12 BUTTON HEAD BOLTS	8MM ALLEN TOOL
5	24	M12 FLAT WASHERS	RATCHET
6	12	M12 LOCK WASHERS	TORQUE WRENCH
7	12	M12 HEX NUTS	2FT EXTENSION (OPTIONAL)
8	4	M12 X 60MM HEX HEAD BOLTS	
9	2	SPACER PLATES(FOR USE ON 09-11 FORD F150)	9/16 DRILL BIT
10	2	M12 45MM BOLT PLATES	DRILL MOTOR
11	2	M12 35MM BOLT PLATES	
12	8	M12 PLASTIC RETAINERS	
13	2	PLASTIC CAPS	
14	1	20 INCHES FISH WIRE	
15	1	1 METER FISH WIRE	

ANTI-SEIZE LUBRICANT MUST BE USED ON ALL STAINLESS STEEL FASTENERS TO PREVENT THREAD DAMAGE AND GALLING

PROCEDURE

1. Remove all contents from box, verify all parts listed are present and free from damage. Carefully read and understand all instructions before attempting installation.

NOTE FOR VEHICLE WITH OVER SIZE TOOL BOXES AN OPTIONAL BRACKET KIT PART # 57-8095/8093 IS AVAILABLE, THESE BRACKETS REPLACE THE DRIVERS AND PASSENGER SIDE MOUNTING BRACKETS.

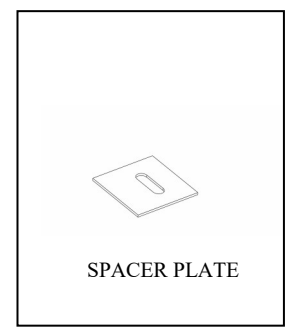
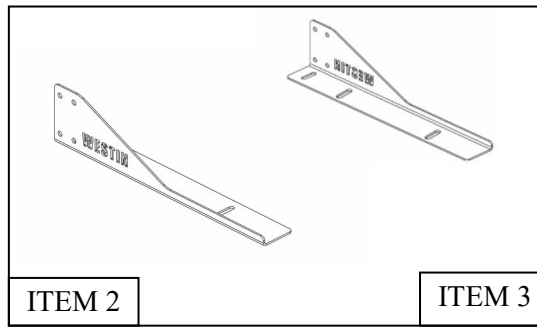
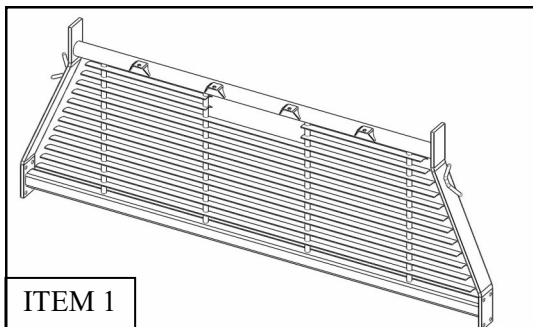

- Assemble the drivers and passenger side mounting brackets to the headache rack using (8) M12 button head bolts, (16) M12 flat washers, (8) M12 lock washers, and (8) M12 hex nuts. Do not fully tighten at this time. **See Figure 1**
- Take the assembled headache rack and place it on the bed rails and center the assembly. Mark the four drill locations then remove the rack and brackets. See Fig. 1

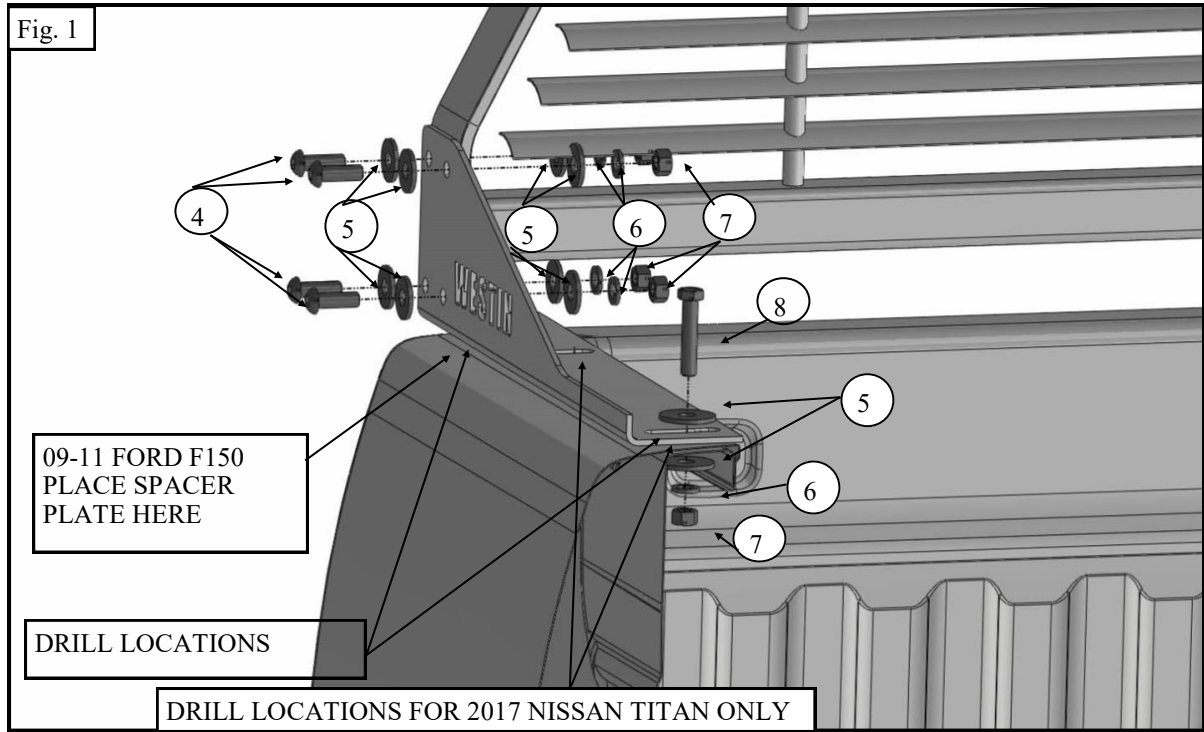

- Drill the previously marked holes with a 9/16" drill bit. NOTE: 09-11 FORD F150's using the factory bed caps should use the provided spacer plates under the front of the mounting brackets to level the headache rack. **For 15-17 F150 and 2017 F250/350/450/550 drilling, hardware to use, and special instructions. See Figures 4 to 8.**
- Install the driver side mounting bracket starting with the forward most mounting location using the options detailed in Figs 1 and 2. Rotating the mounting bracket 90° allows access to the fasteners through the stake pocket. Repeat for passenger side bracket.

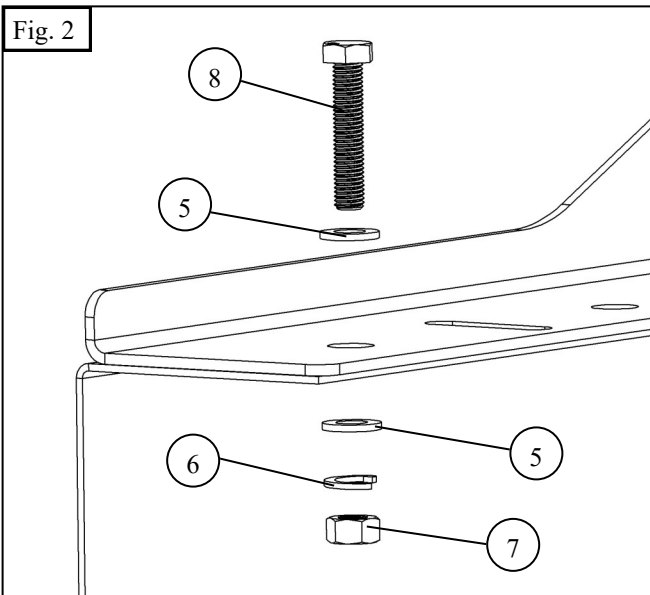

OPTION A: USE THIS BOLT/WASHER/NUT INSTALLATION METHOD IF ACCESS TO THE LOWER NUT IS AVAILABLE. A 2FT RATCHET EXTENSION WORKS WELL FOR THIS.

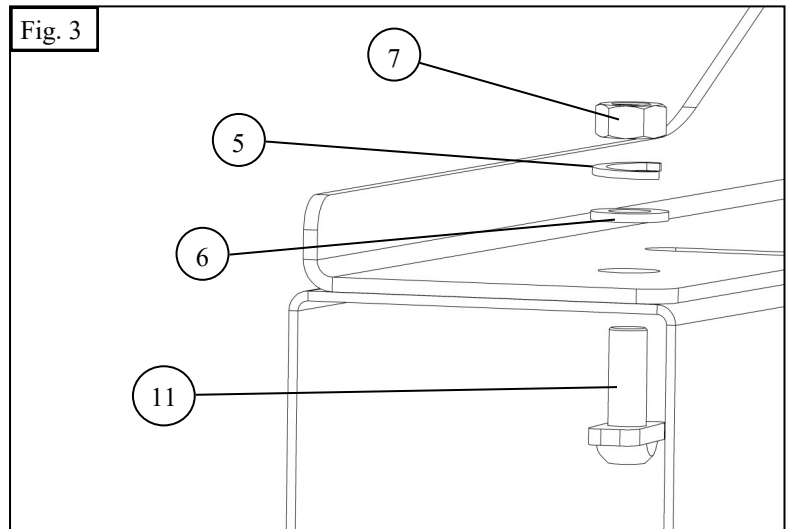

OPTION B: USE THIS BOLT PLATE INSTALLATION METHOD IF THERE IS NO ACCESS FOR OPTION A. USE A PLASTIC RETAINER TO PREVENT THE BOLT PLATE FROM FALLING.

6. Install the headache rack to the mounting brackets as in step 2. NOTE : the light tabs on the upper cross-member face the cab.
7. Align and adjust the headache rack as needed then fully tighten all hardware. Torque all M12 fasteners to 50-55 ft. lbs.
8. Installing the Headache rack on 2015-2017 Ford F150 and 2017 Ford SD F250/350/450/550.
9. Drill the previously marked holes with a 9/16" drill bit. Drill the rear hole at 2 3/8 from the inside edge. And drill the front hole at the center of the oval hole.
10. Place a plastic retainer (Item 12) on each nut plate (Items 10 & 11). And fold them as shows on figures 4 & 5.
11. Place 2 layers of electrical tape around the bolt as shows on figure 6.
- Important: Poly retainer and electrical tape must be used to insulate and prevent the contact between bracket (Made of steel) and truck's body (Made of aluminum). Contact between these two materials creates corrosion.**
12. At the front location insert the 20 in. fish wire into the hole, and pull it front the gap between the bed and the cabin (Figure 7) thread the fish wire onto the 45mm bolt plate (Item 10) and carefully pull the fish wire to insert the nut plate from the bottom into the hole. Use this same procedure for the rear location using the 35mm nut plate (Item 11) and the 1meter Fish wire (Item 15).
13. Proceed to steps 5 to 7. and install plastic caps (Item 13) on rear nut (Figure 8).



FIG 4



FIG 5



FIG 6



FIG 7

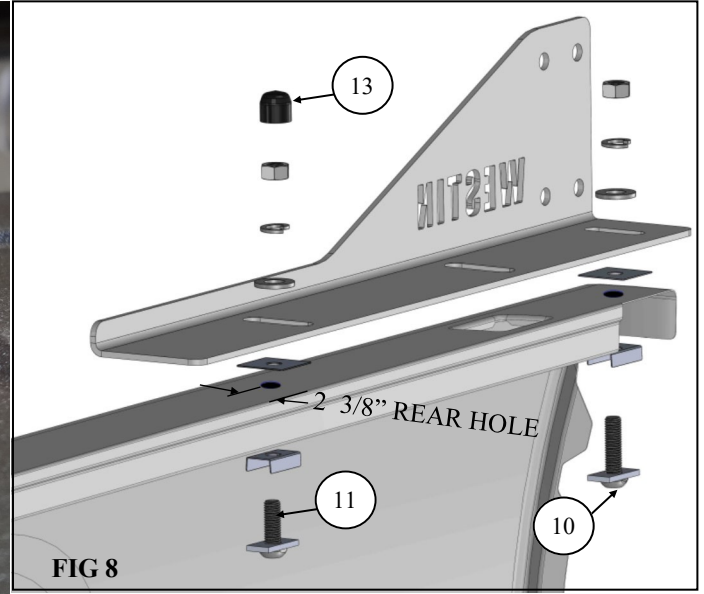

FIG 8

INSTALLATION COMPLETE



CARE INSTRUCTIONS

- REGULAR WAXING IS RECOMMENDED. DO NOT USE ANY TYPE OF POLISH OR WAX THAT MAY CONTAIN ABRASIVES.
- STAINLESS STEEL PRODUCTS CAN BE CLEANED WITH MILD SOAP AND WATER. STAINLESS STEEL POLISH SHOULD BE USED TO POLISH SMALL SCRATCHES.
- GLOSS BLACK FINISHES SHOULD BE CLEANED WITH MILD SOAP AND WATER.

WESTIN Westin Automotive Products, Inc.
320 W. Covina Blvd
San Dimas, Ca. 91773

Thank you for choosing Westin products
for additional installation assistance please call
Customer Service (800) 793-7846
www.westinautomotive.com
DATE: 02/4/2021



WARNING



Failure to follow these instructions could lead to death, personal injury, and / or property damage.

Failure to follow these instructions could lead to death, personal injury, and / or property damage.

FASTENERS:

All Westin supplied fasteners must be utilized and installed in accordance with the installation instructions and apply torque to the specifications as defined. **DOUBLE CHECK ALL FASTENERS BEFORE INITIAL USE, AND PERIODICALLY IN THE FUTURE TO ENSURE PROPER FUNCTION AND SAFETY.**

DRILLING:

Most Westin products do not require drilling for installation. If drilling is defined as required, use caution when drilling a vehicle. **FAILURE TO REVIEW AN AREA TO BE DRILLED MAY RESULT IN PERSONAL INJURY AND/OR INJURY TO OTHERS AS WELL AS VEHICLE DAMAGE.**

EYE PROTECTION:

ALWAYS WEAR SAFETY GLASSES OR GOGGLES DURING THE INSTALLATION PROCESS TO AVOID PERSONAL INJURY.

MAXIMUM TOWING/CARRYING CAPACITY: (if applicable)

The Westin Receiver Hitches will have a visible tow rating label affixed directly on the product. User should never exceed the vehicle manufacturers maximum tow and weight rating regardless of the capacity of the hitch. **FAILURE TO FOLLOW THESE GUIDELINES WILL VOID THE WESTIN WARRANTY AND MAY RESULT IN PERSONAL INJURY AND/OR INJURY TO OTHERS AS WELL AS VEHICLE DAMAGE.**

FOR CALIFORNIA RESIDENTS ONLY-PROP 65 WARNING:

Some products may contain chemicals such as DEHP, which can cause cancer, birth defects or other reproductive harm. For more info go to www.p65warnings.ca.gov



Westin Automotive Products, Inc.
320 W. Covina Blvd
San Dimas, Ca. 91773